

NTISUB/B/104-76/001

AIRCRAFT ACCIDENT REPORT - WIEN AIR ALASKA, INC.,  
FAIRCHILD F-27B, N4904  
GAMBELL, ST. LAWRENCE ISLAND, ALASKA

Bureau of Aviation Safety  
Washington, D. C.

January 1976

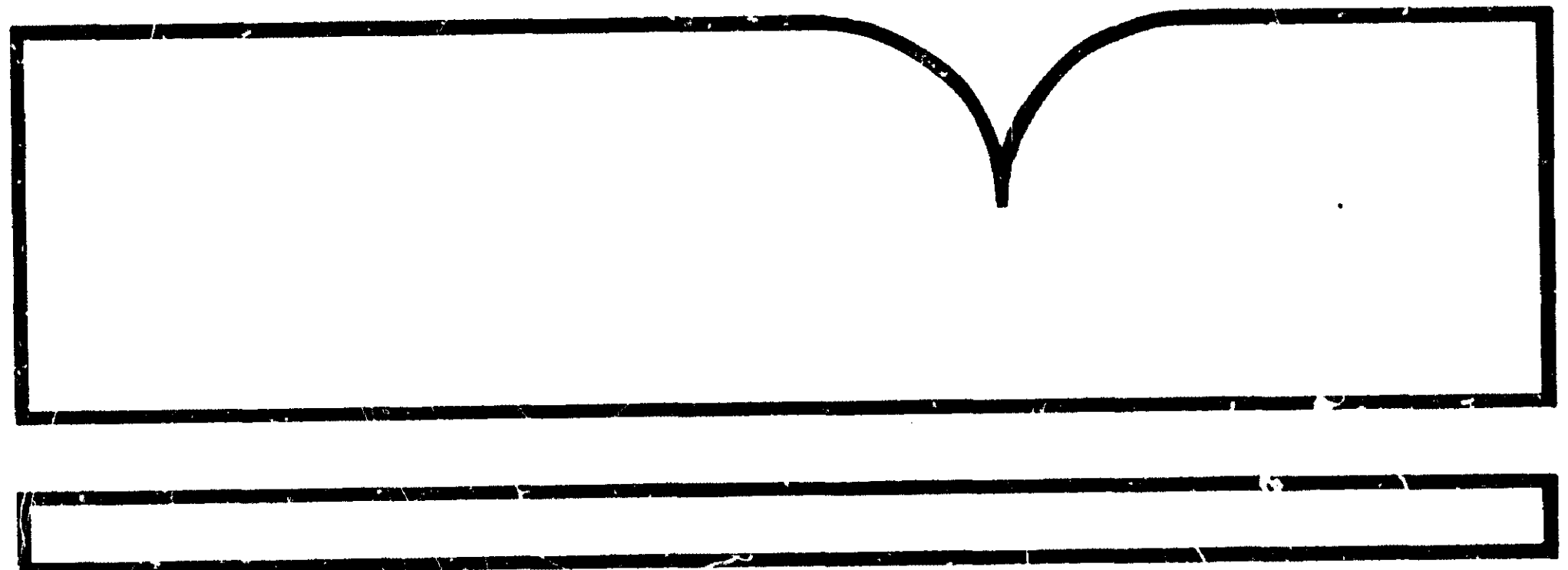

U.S. Department of Commerce  
National Technical Information Service

**NTIS**

TECHNICAL REPORT DOCUMENTATION PAGE

1. Report No. NTSB-AAR-76-1	2. Government Accession No.	3. Recipient's Catalog No.	
4. Title and Subtitle Aircraft Accident Report - Wien Air Alaska, Inc. Fairchild F-27B, N4904 Gambell, St. Lawrence Island, Alaska		5. Report Date January 7, 1976	
		6. Performing Organization Code	
7. Author(s)		8. Performing Organization Report No.	
9. Performing Organization Name and Address National Transportation Safety Board Bureau of Aviation Safety Washington, D.C. 20594		10. Work Unit No. 1717	
		11. Contract or Grant No.	
12. Sponsoring Agency Name and Address  NATIONAL TRANSPORTATION SAFETY BOARD Washington, D. C. 20594		13. Type of Report and Period Covered Aircraft Accident Report August 30, 1975	
		14. Sponsoring Agency Code	
15. Supplementary Notes			
16. Abstract At approximately 1357 Bering daylight time, on August 30, 1975, Wien Air Alaska, Inc., Flight 99, crashed into Sevuokuk Mountain, Gambell, Alaska, while attempting to land at Gambell Airport. There were 28 passengers and 4 crewmembers on board. Seven passengers and three crewmembers were killed; the aircraft was destroyed by impact and fire.  The weather was characterized by low ceilings and low visibilities. Sea fog was reported to be moving in an easterly direction across the airport and toward the mountain.  The National Transportation Safety Board determines that the probable cause of this accident was the flightcrew's failure to adhere to prescribed company instrument approach procedures while attempting to land in adverse weather conditions.			
17. Key Words Low ceilings and visibilities; prescribed company instrument approach procedures; fog; numerous attempts to land.		18. Distribution Statement This document is available through the National Technical Information Service, Springfield, Virginia 22151	
19. Security Classification (of this report) UNCLASSIFIED	20. Security Classification (of this page) UNCLASSIFIED	21. No. of Pages	22. Price

TABLE OF CONTENTS

		<u>Page</u>
	Synopsis . . . . .	1
1.	Investigation . . . . .	1
1.1	History of the Flight . . . . .	1
1.2	Injuries to Persons . . . . .	3
1.3	Damage to Aircraft . . . . .	3
1.4	Other Damage . . . . .	3
1.5	Crew Information . . . . .	3
1.6	Aircraft Information . . . . .	3
1.7	Meteorological Information . . . . .	4
1.8	Aids to Navigation . . . . .	5
1.9	Communications . . . . .	6
1.10	Aerodrome and Ground Facilities . . . . .	6
1.11	Flight Recorders . . . . .	6
1.12	Aircraft Wreckage . . . . .	7
1.13	Medical and Pathological Information . . . . .	8
1.14	Fire . . . . .	9
1.15	Survival Aspects . . . . .	9
1.16	Tests and Research . . . . .	9
1.17	Other Information . . . . .	11
1.17.1	Flight Rules . . . . .	11
1.17.2	Flight Operating Procedures . . . . .	12
2.	Analysis and Conclusions . . . . .	12
2.1	Analysis . . . . .	12
2.2	Conclusions . . . . .	14
	(a) Findings . . . . .	14
	(b) Probable Cause . . . . .	15
Appendixes:		
	Appendix A - Investigation and Hearing . . . . .	17
	Appendix B - Crew Information . . . . .	18
	Appendix C - Aircraft Information . . . . .	20
	Appendix D - Wreckage Distribution Chart . . . . .	23
	Appendix E - Flight Data Recorder Graph . . . . .	25
	Appendix F - Approach Plates for Gambell Airport . . . . .	27
	Appendix G - Cockpit Voice Recording Transcript . . . . .	29
	Appendix H - Tabulation of FDR Parameters . . . . .	42
	Appendix I - Computed Flight Track . . . . .	44
	Appendix J - Recommendations . . . . .	45

NATIONAL TRANSPORTATION SAFETY BOARD  
WASHINGTON, D.C. 20594

AIRCRAFT ACCIDENT REPORT

Adopted: January 7, 1976

---

WIEN AIR ALASKA, INC.  
FAIRCHILD F-27B, N4904  
GAMBELL, ST. LAWRENCE ISLAND, ALASKA  
AUGUST 30, 1975

SYNOPSIS

At approximately 1357 Bering daylight time, August 30, 1975, Wien Air Alaska, Inc., Flight 99, crashed into Sevuokuk Mountain, Gambell, Alaska, while attempting to land at Gambell Airport. There were 28 passengers and 4 crewmembers on board. Seven passengers and three crewmembers were killed; the aircraft was destroyed by impact and fire.

The weather was characterized by low ceilings and low visibilities. Sea fog was reported to be moving in an easterly direction across the airport and toward the mountain.

The National Transportation Safety Board determines that the probable cause of this accident was the flightcrew's failure to adhere to prescribed company instrument approach procedures while attempting to land in adverse weather conditions.

1 INVESTIGATION

1.1 History of the Flight

Wien Air Alaska Flight 99, a Fairchild F-27B, N4904, was a regularly scheduled passenger and cargo flight from Nome, Alaska, to Savoonga and Gambell--two villages on St. Lawrence Island, Alaska.

The captain's VFR flight plan, as filed with the Nome Flight Service Station (FSS), indicated a route of flight from Nome to Savoonga, via Island Intersection, then to Gambell, with a return to Nome via Island Intersection. The requested altitude was 12,000 feet 1/ and the listed alternate airports were Galena and Nome.

---

1/ All altitudes herein are mean sea level.

At 1216, 2/ on August 30, 1975, Flight 99 departed Nome and landed at Savoonga at 1306. The aircraft departed Savoonga at 1327 with an estimated time en route of 15 minutes to Gambell. There were 32 persons on board--28 passengers and 4 crewmembers.

When the Wien agent at Gambell heard Flight 99's radio transmissions after takeoff from Savoonga, she activated the Gambell Nondirectional Beacon (NDB).

According to the cockpit voice recorder (CVR) transcript, the crew identified the Gambell NDB shortly after departing Savoonga and contacted the Wien agent at Gambell. (See Appendix G.) The crew gave their estimated time of arrival and requested the weather. The agent replied, "Our current weather is partial obscured sky. Visibility 1 to 1/2 miles ... 1 mile to 1/2 mile with ... and fog. Temperature is 47°, wind is calm, altimeter 29.70." Soon thereafter, Flight 99 questioned the visibility; the agent replied that it was, "sometimes about 5 miles, it's very hard to tell ...."

When the flight arrived in the Gambell area, the captain, who was flying the aircraft, remarked to the first officer that fog appeared to be a problem. He also stated, "We'll take a shot from this way and if we can't make it, we'll come around and hit it from that side. If we can't make it from there, we'll turn out and (come in underneath it)." 3/

The pilot then made several attempts to land. According to some surviving passengers, the aircraft descended to a low altitude over the tundra to the south of the airport during one of the approaches.

During another of the approaches, ground witnesses saw the aircraft make a low pass down the runway and then a right turn out to sea before it disappeared into the fog. Some of the survivors, including the flight attendant, believed that the aircraft touched down on this approach. The CVR indicates that the crew had the runway in sight but decided to execute a missed approach because they were too far down the runway to land safely. Flight data recorder (FDR) information shows that the aircraft descended to within a few feet of the surface.

According to correlated CVR/FDR information, the aircraft then turned right, flew north, and make a relatively steep turn to the right. During this turn, the first officer said that a 155° heading inbound would be perfect. Cockpit conversations during the rollout indicated that the flight passed the NDB while on a heading of 140°. The captain then called for final flaps and landing gear.

---

2/ All times herein are Bering daylight, based on the 24-hour clock.

3/ Text between parentheses is questionable.

When last observed by ground witnesses, the aircraft was heading southeast. It flew over a beach and near boat racks located about 240 yards northeast of the NDB. It continued its course and passed over the eastern end of some newly constructed houses just north of Troutman Lake, which is located between the runway and Sevuokuk Mountain. Ground witnesses stated that the landing gear was lowered before they saw the aircraft disappear into the fog. Ground witnesses and survivors of the crash generally agreed that there was a considerable amount of patchy fog in the area and that visibility ranged from 1/4 to 1 1/2 miles.

A heading of 140° was maintained for about 28 seconds until the aircraft struck Sevuokuk Mountain at an altitude of 424 feet. Several of the passengers could see the ground and were aware of their position relative to the village of Gambell. Some of them realized that the aircraft was going to hit the mountain and braced themselves.

Shortly after the aircraft entered the fog and just before impact, some witnesses and survivors heard an increase in engine sound.

The impact area was at latitude 63°45'54"N and longitude 171°42'30"W. The accident occurred in daylight.

#### 1.2 Injuries to Persons

<u>Injuries</u>	<u>Crew</u>	<u>Passengers</u>	<u>Other</u>
Fatal	3	7	0
Nonfatal	1	21	0
None	0	0	

#### 1.3 Damage to Aircraft

The aircraft was destroyed.

#### 1.4 Other Damage

None.

#### 1.5 Crew Information

The crewmembers were qualified and certificated according to Federal Aviation Administration (FAA) regulations. (See Appendix B.)

#### 1.6 Aircraft Information

The aircraft was certificated and maintained according to FAA regulations. The aircraft's gross weight at takeoff from Savoonga was 36,753 lbs.; there were 5,850 lbs. of Jet A-50 (Jet A-1) fuel aboard. The weight and center of gravity (c.g.) were within limits.

There was no evidence to indicate any failure or malfunction of the aircraft structure, systems, or powerplants when the aircraft departed Nome. (See Appendix C.)

### 1.7 Meteorological Information

The National Weather Service (NWS) does not receive official weather reports or issue routine forecasts for St. Lawrence Island. However, the Wien Air Alaska Agent at Gambell is certificated by the NWS and provides company weather information via high frequency radio to the Wien dispatch office in Nome. Additional weather information is received from another airline that also operates in the St. Lawrence Island area.

On August 29, 1975, a large but moderate cyclonic area was centered off the eastern Siberian Coast. This system was moving steadily eastward into the Bering Sea. As the system approached the west coast of Alaska, a surface low-pressure area developed just south of Norton Sound and became the predominant center. Winds at surface level around this system were reported at 10 to 15 kn. Over St. Lawrence Island, the pressure gradient, as measured on a surface weather chart, indicated winds of approximately 20 kn.

According to the Fairbanks NWS forecaster, the weather conditions on St. Lawrence Island are frequently similar to those at Nome. The terminal weather forecast for Nome for a 24-hour period beginning at 1200 on August 30 was, in part, as follows:

Ceiling--300 feet broken, visibility--2 miles  
in light drizzle and fog, wind--1900 at 20 kn.,  
variable ceiling to 800 feet broken.

When Flight 99 departed Nome, the ceilings were 500 feet or less and the visibility varied from 3 to 7 miles with drizzle and fog. The crew of Flight 99 were informed of these conditions, as well as the current Island weather, before leaving Nome. The current St. Lawrence weather as given by Wien Dispatch was:

Savoonga 1030 - Estimated 600 overcast, visibility--10  
miles in rain, temperature--60°F.,  
wind--250° at 9 kn., altimeter  
setting--29.67 in.

Gambell 1031 -- Ceiling obscured, visibility--1 mile in  
rain and fog, temperature--47°F.,  
wind--200° at 9 kn., altimeter  
setting--29.70 in.

### 1.8 Aids to Navigation

The Gambell Airport is equipped with an 80 watt "H" class nondirectional radio beacon which is operated by Wien Air Alaska, Inc. The beacon operates on a frequency of 209 kHz; it is powered by a local AC generator with no standby power source and is operated only by radio request. The facility is flight checked by the FAA; the most recent check before the accident was on June 4, 1975. A flight check of the beacon after the accident indicated that all parameters were satisfactory except for the voice feature.

On September 9, 1972, the NDB was relocated from within the village to a position northeast of the main village area. On September 20, 1972, the facility was flight checked and no discrepancies were noted.

On September 10, 1975, an FAA air carrier avionics inspector measured the distance of the antenna from its previous location. These measurements indicated that the antenna had been displaced about 1,200 feet. According to FAA criteria, the change does not warrant a revision of the approach plates for the airport.

The Gambell NDB-A Company approach plate was last revised on February 4, 1972, with an effective date of February 11, 1972. (See Appendix F.) This approach plate depicts the approach to runway 16. After the NDB is intercepted, the plate calls for a heading of 335° and a descent from 1,600 feet to 1,000 feet after the aircraft has proceeded outbound from the NDB for at least 5 miles. The procedure turn is made to the west and within 15 miles of the NDB, after which the plate prescribes descent to the minimum descent altitude (MDA) of 500 feet on a heading of 155°. If visual flight conditions cannot be maintained from the MDA inbound to the NDB and to the airport, a missed approach must be executed. The approach plate depicts the inbound heading of 155° to be along the extended centerline of the runway.

The NDB-B approach to runway 34 calls for a MDA of 980 feet to the NDB and, if visual flight cannot be accomplished, a missed approach must be executed to the west. (See Appendix F.)

Safety Board investigators questioned several pilots, who had knowledge of current procedures at Gambell, regarding the approach. Although most agreed on the normal procedures to be followed for the approach, all pilots did not agree on the physical location of the radio beacon. All pilots agreed that a problem existed regarding operation of the radio beacon, notably that it is not unusual for the Company radio operator to turn it off (with an approach in progress) in order to communicate with another Wien station on HF radio. Such a procedure is necessary in order to supply adequate power to the HF radio. However,



as the result of the operator's testimony, power company records, examination of the aircraft's automatic direction finders (ADF), and review of the cockpit voice recorder transcript, there is no evidence that the beacon was inoperative at any time while Flight 99 was attempting to land.

#### 1.9 Communications

There were no communications difficulties reported between Flight 99 and control facilities.

#### 1.10 Aerodrome and Ground Facilities

Gambell Airport, located adjacent to the Village of Gambell on the northwest tip of St. Lawrence Island, is owned by the State of Alaska and operated by its Division of Aviation. The airport is certificated for air carrier operations under the provisions of 14 CFR 139.

Runway 16/34 is of asphalt construction, is 4,500 ft. long and 100 ft. wide, and is oriented southeast/northwest. The airfield has a 150 ft. by 300 ft. parking area at the north end, with a rotating light beacon adjacent to the parking area. The runway has elevated runway lights.

An inspection of the airfield revealed that the rotating light beacon had an operational motor and intact lenses, but the light bulb was defective. A Notice to Airman (NOTAM) had not been issued regarding the inoperative beacon light. The runway system was in need of repair-- several lights did not function and some light stanchions or supports had been knocked down. There are no visual approach aids or runway centerline markings. There is no crash fire/rescue equipment. The airport was exempted from the provisions of 14 CFR 139.49 by the FAA. The exemption is in effect until January 1, 1979.

#### 1.11 Flight Recorders

The aircraft was equipped with a Sundstrand Model V-557 cockpit voice recorder, serial No. 1609. The unit was not damaged and, although the shockmounts had collapsed, the mount itself was not deformed. (See Appendix G.)

The aircraft was also equipped with a Sundstrand Model FA-542 flight data recorder, serial No. 3502. The FDR receives its altitude and airspeed information from the first officer's pitot and static systems and its magnetic heading information from the No. 2 compass system. The FDR was undamaged. Although all traces had been recorded clearly, the airspeed and altitude traces were recorded in reverse, that is, going down to increase and up to decrease. This reversal in airspeed and altitude traces prevailed on all of the previous 268 flights. (See Appendix E.)

Examination by Wien Air Alaska showed that this discrepancy could have resulted from reversal of dynamic and static pressure inputs to the FDR. Altitude and airspeed traces recorded on the foil represent pressure differentials sensed by the FDR. However, when the inputs are reversed, the recorded pressures cannot be translated directly into the correct altitudes or airspeeds without additional calibration and computation.

The flight recorder was sent to the manufacturer, Sundstrand Data Control, where a calibration of airspeed between 100 kn. and 230 kn. was performed by simulating reversed dynamic and static pressure sources to the recorder.

By applying this airspeed calibration to the raw data from the airspeed trace on the FDR, reasonable values of indicated airspeed were obtained. The airspeed values produced by this calibration, together with raw data from a readout of the altitude trace, were used in a computer program to calculate values of m.s.l. altitudes. (See Appendix H.) Review of the computed airspeeds and altitudes showed that the flight descended below 500 feet m.s.l. several times during the attempts to land at Gambell. Review of the heading traces showed that none of the approaches was within the prescribed instrument approach procedures. The approximate heading at impact was 140°. (See Appendix I.)

#### 1.12 Aircraft Wreckage

The aircraft crashed into the northwest slope of Sevuokuk Mountain at an altitude of 424 feet. The first impact mark was found 134 feet below a 558-foot ridge. The aircraft overturned during the crash and came to rest inverted and heading opposite the direction of flight. The wreckage was distributed on a magnetic heading of 140°. Except for a part of the left and right main landing gears, the wreckage was confined to an area 248 ft. long and 80 ft. wide. (See Appendix D.)

Examination of the aircraft did not reveal any preimpact structural failures, flight control malfunctions, system failures or in-flight fire. The aircraft was destroyed by impact and the ensuing ground fire.

Examination of the landing gear and wing flap components revealed that the landing gears were extended and that the flaps were about 16 1/2° at the time of impact.

Both alternating current inverters were examined; one revealed heavy internal rotational scoring on its commutator.

Two light bulbs from the empennage navigation lights and one from the left wingtip were examined; the filaments in the three bulbs were elongated.

The two ADF receivers and antennas, a gyrosyn compass, the face plates of the two radio magnetic indicators and the radio altimeter and radio transmitter were removed for examination.

The direct-current light bulb (which indicates power-failure for the captain's compass had been broken and no meaningful information was obtained; however, the corresponding bulb for the first officer's compass was intact. Examination of it revealed that the filament had broken where it went through the support post. The filament coils were not stretched.

The No. 1 engine had separated at the compressor casing which exposed the first-stage impeller. The impeller blades were bent opposite the direction of rotation. The air intake casing showed evidence of severe scraping or rubbing by the first-stage compressor.

The No. 2 engine reduction gear casing was sheared off, thereby exposing the broken reduction gear drive shaft. The compressor blades were bent opposite the direction of rotation and had impacted into the air intake casing.

Examination of the No. 1 propeller with its separated No. 4 blade and the No. 2 propeller showed all propeller blades bent back opposite the direction of rotation.

Most of the cabin furnishings were burned severely. Examination of the passenger seat structures revealed numerous failures of leg supports and seat-to-floor attachments. Some seat legs were bent forward and a few horizontal seat supports were bent downward. No passenger seatbelts failed.

The three cockpit seats were damaged extensively by impact, and pieces of the seats were widely scattered in the wreckage. The flight attendant seat had been torn from its attachments and was found away from its normal location.

#### 1.13 Medical and Pathological Information

Post-mortem examination of the captain and first officer disclosed no evidence of incapacitating disease. Toxicological analyses for drugs, alcohol, and carbon monoxide revealed no significant findings. The captain, first officer, and cargo-loader received multiple, extreme impact injuries. The captain and cargo-loader were burned severely.

The seven fatally injured passengers sustained severe impact injuries and three of them were burned extensively; toxicological analyses of the latter revealed negative findings for carbon monoxide.

Two of the 21 surviving passengers escaped with only minor injuries. The remaining 19 received various impact injuries, including leg and

arm fractures, multiple cuts, abrasions, and contusions. Three of the most seriously injured passengers received multiple fractures. The flight attendant had fractures of both legs and other impact injuries.

#### 1.14 Fire

The survivors reported that fire erupted in the vicinity of the left engine immediately after the crash. They said that the fire spread slowly, but gradually to the cabin area, which provided time for the rescue of all but one of the injured passengers.

The crash site was accessible only to hand-held fire extinguishers, which the local residents carried to the scene and used on the fire. The fire eventually burned itself out.

#### 1.15 Survival Aspects

This accident was partially survivable. The decelerative forces were within human tolerance; however, the aircraft sustained severe structural damage and overturned. Most seats came loose when the floor lost its structural integrity. Some occupiable areas of the aircraft, including the cockpit, were crushed.

In addition, there was sufficient time for the survivors to escape or to be rescued before the fire intensified. Some passengers escaped from the wreckage unaided. An Alaska State Trooper, who was a passenger, rescued approximately 15 survivors from the wreckage. The Trooper said that nearly all survivors had to be unbuckled from their seats which, in most cases, had broken loose and were piled up. After he had the survivors out of the aircraft, he carried them away from the wreckage. He was assisted by local residents who arrived at the scene about 30 minutes after the accident.

#### 1.16 Tests and Research

On September 1, 1975, a combination profile flight and aerial photo mission was flown in N4903, a Wien Air Alaska F-27B.

During the flight, two NDB-A approaches were made using the Gambell beacon. During the flight the ADF indicators, at times, momentarily oscillated ( $\pm 3^\circ$  max.). The first officer's indicator momentarily lost the signal twice during the approach, but both times the indicator needle came back to the correct indication. At the beacon there was a marked deflection of the needle and a positive indication of station passage.

The first approach was continued beyond the beacon to evaluate the bearing between the aircraft and the runway compared to that depicted on the approach plate. When the NDB was passed on an indicated heading of  $157^\circ$ ; the track of the aircraft was over the center of Troutman Lake and parallel to, but to the left of, the runway.

A second approach with an inbound track of  $155^{\circ}$  resulted in a ground track that was slightly farther left. Because of the physical location of the Gambell NDB, a properly executed approach with an inbound heading of  $155^{\circ}$  will result in an aircraft's passing to the left of the runway.

Next, a low approach from the north was made followed by a  $180^{\circ}$  right turn to sea and a rate of turn established so that the first officer could keep the shoreline in sight. The aircraft was flown north along the shoreline and past the cape, after which a steep right turn was initiated. The aircraft was turned to a heading that took it slightly to the east of a boat rack and toward the crash site. (See Appendix D.) The approximate heading was  $140^{\circ}$ . Three minutes 16 seconds elapsed from initiation of the right turn after the low approach to the accident scene. The approximate time from the boat racks to the accident site was 26 seconds.

After the aircraft returned to Anchorage, both ADF receivers were checked. No discrepancies were noted and both were within tolerances.

The two automatic direction finder receivers and antennas were examined at the Wien Air Alaska, Inc., facilities. The function switches on both receivers were on band No. 1 and the tuning capacitors of both receivers were found within  $\pm 2^{\circ}$  of 209 kHz (Gambell radio beacon). The radio assembly from the No. 1 ADF receiver was connected to the frame assembly of a functional unit, and it operated normally. ADF bearing and sensitivity met or exceeded manufacturer's specifications. Impact and fire damage prevented testing of the No. 2 ADF receiver.

The No. 1 ADF antenna had separated from the aircraft and was damaged. About  $3/4$  of the ferrite rotor of the antenna was still intact and by observing the bearing reference mark on the rotor, it was determined that the rotor had stopped at a bearing of about  $185^{\circ}$  relative to the nose of the aircraft. However, the rotor was not completely frozen in this position; it was stuck, requiring moderate force to move it because the gear teeth in the gear train were dented. A bench test of the bearing synchro output of this antenna verified that, in the stalled position, a bearing of about  $182^{\circ}$  to  $185^{\circ}$  was observed on a synchro receiver (ADF indicator). According to these test results, the station received was behind the aircraft.

The No. 2 ADF loop antenna also had been separated and damaged. The ferrite rotor of this antenna was completely destroyed, but the three wires from the loop coils in the rotor remained in the hub of the rotor. By comparing the relative positions of these three wires in the rotors of the two antennas, it was determined that both loop antennas were aligned to the same relative bearing,  $\pm 5^{\circ}$ .

Bench test of the bearing synchro output of the No. 2 antenna showed that when it was in the locked position, the ADF synchro indicator showed a relative bearing of about  $173^{\circ}$  to  $176^{\circ}$ , also indicating that the station was behind the aircraft.

Parts from a gyrosyn compass were examined at a Wien Air repair station. Although no definite information was obtained during the examination, based on the damage to the rotating compass card, the heading at the time the instrument was damaged was estimated to be  $120^{\circ}$ ,  $\pm 10^{\circ}$ . The parts were then examined at the manufacturer's facilities. Conclusive findings regarding compass card indications at impact could not be made except for possible readings of  $30^{\circ}$  or  $120^{\circ}$ . The manufacturer stated that gyroscopic characteristics are such that initial impact forces could cause rapid precession, resulting in any random reading at the time the instrument was damaged.

Based on examination of the impact marks on the face plates of the two radio magnetic indicators, the Safety Board determined that one plate was indicating about  $120^{\circ}$  and the other plate was indicating about  $125^{\circ}$  when damaged during the crash sequence.

The radio altimeter and radio transmitter units were examined at the Wien Air Alaska radio shop. The radio transmitter functioned normally when bench tested. Basic sensitivity, power, and output were within manufacturer's specifications. The altitude pointer of the radar altimeter was at 80 ft. The MDA index was set at 100 ft., and the flag was in view.

#### 1.17 Other Information

##### 1.17.1 Flight Rules

At latitude  $63^{\circ} 45' N$  and longitude  $168^{\circ} 40' W$ , a flight from Nome to St. Lawrence Island must transition from the Alaskan Domestic Air Defense Identification Zone (ADIZ) to the Alaskan Distant Early Warning Identification Zone (DEWIZ).

On entry into the Alaska DEWIZ, the aircraft is governed by 14 CFR 91.105 for VFR flight operations. This regulation requires that the area in which the aircraft is operating have at least 1 mile visibility and that the aircraft remain clear of clouds if below 1,200 feet.

Since there is no controlled airspace at Gambell or Savoonga, direct ATC communications are not essential. However, when beginning an instrument approach at either Gambell or Savoonga, a flightcrew will announce their intentions on the company frequency.

### 1.17.2 Flight Operating Procedures

Volume No. 1 of the FAA-approved Operations Manual for Wien Air Alaska, Inc., requires the following crew activities during instrument approaches:

#### "INSTRUMENT APPROACHES

All instrument approaches have certain basics in common. These are good descent planning, careful review of the approach plates, accurate flying and good crew coordination.

The DESCENT and APPROACH checkist must be completed prior to commencing the instrument approach so that the pilot can give his undivided attention to flying the airplane.

#### "Approach Plate

Both pilots will review the approach plate prior to reaching the approach fix. The pilot flying will specify the radio aids required and will crosscheck that the correct aids have been selected, tuned and identified. The pilot not flying will call out field elevation, MDA or DH, and the missed approach procedure.

#### "Standard Callouts

The pilot not flying will utilize the Standard Callouts as tabulated in this section. With each callout, include any significant deviation. The pilot flying will check his instruments and acknowledge these callouts, crosscheck his instruments as convenient and take appropriate action."

## 2. ANALYSIS AND CONCLUSIONS

### 2.1 Analysis

The aircraft was certificated and maintained in accordance with existing regulations. The crewmembers were qualified and certificated to conduct the flight. There was no evidence of in-flight fire or explosion, structural failure, flight control malfunction, or systems failure. The aircraft's weight and c.g. were within limits throughout the flight.

The witnesses' and survivors' statements, the CVR transcript, and the FDR information indicate that the captain did not follow the prescribed instrument approach procedures during any of his several attempts to land. It is also evident that he continued to fly in and out of instrument flight conditions in an area and at altitudes where visual flight was mandatory.



Reasons for Deviation

In an effort to determine the captain's reasons for continuing on a magnetic heading of 140°, the Safety Board considered the following factors:

First, the Safety Board considered the possibility of a malfunction of the ADF receivers; we could find no evidence of such a malfunction. Both ADF receivers were tuned properly to the Cambell NDB frequency. Examination of the two ADF antennas verified that they were pointing back toward the NDB. In addition, recent maintenance history, interviews with pilots who had flown the aircraft, and the CVR transcript do not support the likelihood of a malfunction.

Second, the Safety Board considered the possibility of misleading heading information on the radio magnetic indicators (RMI) as a result of a malfunctioning compass system or gyroscopic precession during the last turn. Since the impact heading recorded by the FDR, which receives its information from the first officer's compass system, corresponded closely to the actual impact heading, the possibility that misleading heading information was being portrayed in the cockpit is remote.

To explain the difference in impact heading recorded by the FDR and the headings obtained from impact markings on the RMI face plates and the gyrosyn compass card, the damage to the tail section at initial impact must be considered. Since the FDR is located in the tail section, this damage probably disrupted all inputs to the FDR at initial impact. As long as electrical power remained available to the gyrosyn compass and RMI's, directional changes during the impact sequences and gyroscopic precession induced by impact forces could affect gyrosyn and RMI readings until these components were damaged by impact. Therefore, the earlier mentioned difference in FDR heading information and the reading at impact of the gyrosyn compass card and the RMI's is not considered pertinent to the accident.

Finally, the Safety Board considered the possibility that the pilots, in their efforts to sight the runway, were not devoting full attention to monitoring directional instrument indications. Their activities during earlier approaches indicate that they were attempting to maintain visual flight which would have detracted their attentions from the cockpit instruments. The Safety Board believes that they were also attempting to maintain visual flight during their final landing attempt. According to facts obtained by correlation of the FDR and CVR, during the aircraft's right turn north of the NDB, the first officer stated that a 155° heading inbound would have been perfect. However, there is no evidence to indicate that the captain terminated the right turn on that heading. He was probably relying on visual cues at that time.



When the first officer called, "over the beacon," the aircraft was actually east of the beacon and could be seen by ground witnesses. In addition, some passengers could see the ground to the extent that they knew that the aircraft was headed toward the mountain. Therefore, the flightcrew also could see the surface intermittently at that time. However, their perspective was different from that of the passengers and they may have only had a fleeting glimpse of the lake's eastern shoreline. Thus, they could have been disoriented and may have assumed that they saw the Bering Sea shoreline, west of the airport.

The role of the inoperative rotating beacon light is difficult to assess. It is possible that an operating beacon might have been sighted by the crew, thereby leading them to their incorrect position with regard to the runway.

In conclusion, the accident would have been avoided if the NDB-A approach procedure had been followed, especially with regard to the making of a standard procedure turn; this would have allowed the captain to establish the aircraft on the proper inbound track for descent, to establish visual reference at MDA for proceeding to the airport, or to execute a timely missed approach if adequate visual reference was not obtained at MDA before reaching the NDB.

The Safety Board stresses to all pilots that it is imperative to fly instrument approach procedures precisely and in conformance with prescribed limitations.

#### Survivability

Many aircraft occupants survived the accident because of the low-impact forces. Although passenger seatbelts, which are fastened to the seats, did not fail, nearly all of the seats broke loose when the fuselage floor lost its structural integrity. This loss of seat restraint and the random manner in which the occupants came to rest caused nearly all of the impact injuries. Crushing injuries were sustained in the cockpit and in other areas where environmental structures impinged on the occupants.

The actions of the Alaska State Trooper, the local residents, and others involved in the rescue and evacuation of the injured prevented greater losses of life.

## 2.2 Conclusions

### (a) Findings

1. The aircraft was certificated and maintained according to approved procedures.
2. All crewmembers were certificated and qualified for the flight.

3. Weather in the area of the flight was below authorized minimums for an approach.
4. The NDB was operating properly.
5. Both of the aircraft's ADF's were operating properly.
6. There was no evidence of a malfunction or precession of the aircraft compass system.
7. The crew did not comply with approved instrument approach procedures during several attempts to land in instrument flight conditions.
8. The runway rotating light beacon was not operating.
9. The occupant's injuries were caused by loss of restraint and crushing of some areas of the aircraft.
10. The fire propagation rate was slow, permitting the escape and rescue of all but one of the trapped occupants.

(b) Probable Cause

The National Transportation Safety Board determines that the probable cause of this accident was the flightcrew's failure to adhere to prescribed company instrument approach procedures while attempting to land in adverse weather conditions.

BY THE NATIONAL TRANSPORTATION SAFETY BOARD

/s/ JOHN H. REED  
Chairman

/s/ FRANCIS H. McADAMS  
Member

/s/ LOUIS M. THAYER  
Member

/s/ ISABEL A. BURGESS  
Member

/s/ WILLIAM R. HALEY  
Member

January 7, 1976

APPENDIX A

INVESTIGATION AND HEARING

1. Investigation

The National Transportation Safety Board was notified of the accident at 2027 e.d.t., on August 30, 1975, by the FAA Communications Center in Washington, D. C. An investigation team arrived on the scene at approximately 1630 e.d.t., on August 31, 1975. A working group was established for operations, weather, air traffic control, and witnesses. Other working groups established were systems, structures and maintenance records, and human factors.

Parties to the investigation were the Federal Aviation Administration, Wien Air Alaska, Inc., Fairchild Republic Co., Air Line Pilots Association, Association of Flight Attendants, and the Division of Aviation of the State of Alaska.

2. Hearing

A public hearing was not held.

APPENDIX B

CREW INFORMATION

Captain William C. Arant

Captain William C. Arant, 39, was employed by Wien Air Alaska, Inc., on April 17, 1967. He held Airline Transport Pilot Certificate No. 1617282 with type ratings in the F-27, and commercial privileges, airplane, single engine land. He had accumulated 6,607 hours, of which 4,626 were in the F-27/227. His total pilot time in type for the last 90 days was 241 hours. His total instrument time was 343 hours with 185 hours in type. He completed his recurrent training in November 1974. His last proficiency check was accomplished in a simulator August 5, 1975, and his last line check on May 2, 1975.

He received a type rating on the F-27 on April 29, 1974. An FAA inspector observed this check and an en route inspection on June 7, 1974.

Captain Arant had a rest period of 2 days before he reported for this trip. At the time of the accident, he had been on duty about 9 hours.

Captain Arant had flown into Gambell seven times within the last 6 months; however, he had not been there within the last month.

His last FAA first-class medical certificate was issued on April 23, 1975, with the limitation that he wear corrective glasses while exercising the privileges of his airman certificate. It was not determined whether Captain Arant was wearing his glasses at the time of the accident; however, other pilots who had flown with him previously stated that he always wore his glasses while flying.

First Officer Gerald W. Schaefer

First Officer Gerald W. Schaefer, 28, was employed by Wien Air Alaska, Inc., on April 11, 1974. He held Airline Transport Pilot Certificate No. 2026927 with type ratings in the F-27/227 and commercial privileges, airplane, single engine land. He had accumulated 2,738 flight-hours, of which 470 were in the F-27/227. His total pilot time in type for the last 90 days was 215 hours. His total instrument time was 194 hours with 30 hours in type. He completed his last proficiency check in a simulator on April 7, 1975.

He had flown into Gambell Airport within the last 15 days and within the last 6 months he had flown there 5 times.

APPENDIX B

He had a rest period of 10 hours 15 minutes before he reported for this trip. At the time of the accident, he had been on duty for about 9 hours.

His FAA first-class medical certificate was issued July 30, 1975, with the limitation that he must wear glasses for distant vision while flying. It was determined during post-mortem examination that Mr. Schaefer was wearing contact lenses at the time of the accident.

Investigation into the activities of the flightcrew for the 72 hours preceding the accident did not reveal any findings that were significant.

Flight Attendant Marsha D. Berger

Flight Attendant Marsha D. Berger was employed by Wien Air Alaska, Inc., on February 18, 1975. Her initial training was completed March 6, 1975. She completed flight assignment to the F-27 aircraft on April 2, 1975.

Cargo Loader Arthur Outwater

Cargo Loader Arthur Outwater was employed by Wien Air Alaska, Inc., on August 15, 1975. He had completed general training on loading and unloading aircraft and parking aircraft, and was qualified on various pieces of ground support equipment.

APPENDIX C

AIRCRAFT INFORMATION

The aircraft, serial No. 21, was purchased new by Northern Consolidated Airlines (Wien Air Alaska, Inc.,) on October 28, 1958, and has been operated continuously by the present owners.

At an aircraft time of 2397:20 the aircraft was extensively damaged when the right landing gear collapsed in the hangar during maintenance to that gear. Temporary repairs were made to the wing and belly and a permit was issued on May 2, 1973, to ferry the aircraft to Fairchild, Hagerstown, Maryland, for inspection, overhaul, modifications, and compliance with selected Service Bulletins.

The aircraft was released by Fairchild to WAA on 12/4/73, and from there it was ferried to American Jet Industries, Burbank, California, for refurbishing of the interior.

According to American Jet Industries all materials used for the bulkhead covering, cabin rug, cabin side panels, headliner and aft cabin air ducts were burn tested on February 18, 1974, and all pieces self-extinguished.

The aircraft was ferried from Burbank, California, to Anchorage, Alaska, by WAA flightcrews on February 25, 1974, and the first scheduled flight since overhaul was flown on March 1, 1974.

On August 29, 1975, the aircraft's total time was 26,068:25 hours.

1. Engines

The aircraft was equipped with Rolls Royce Model RDa 514.7 engines.

The No. 1 engine (S/N 12087) was installed on November 15, 1972. The time since last overhaul was 2,606:20 hours, and the last routine inspection was accomplished on August 21, 1975, at Anchorage.

The No. 2 engine (S/N 12088) was installed on August 12, 1974. The time since last overhaul was 1,736:16 hours, and the last routine inspection was accomplished on August 21, 1975, at Anchorage.

2. Propellers

The aircraft was equipped with Dowty Rotol Model R-175-430-4/13E propellers. The No. 1 propeller (S/N 58/132) was installed on November 15, 1972. The time since last overhaul was 2,606:16 hours, and the last routine inspection was accomplished on August 21, 1975, at Anchorage.

The No. 2 propeller (S/N 58/57) was installed on August 12, 1974. The time since last overhaul was 1,736:16 hours, and the last routine inspection was accomplished on August 21, 1975, at Anchorage.

3. Aircraft Flight Logs

The aircraft flight logs were reviewed for a period of 90 days prior to the day of the accident. The last recorded ADF discrepancy was entered on August 11, 1975, with corrective action taken. The last flight log, dated August 29, 1975, which was the day before the accident, had no discrepancies that could be considered relevant to this accident. A proper maintenance release was signed off on Log Sheet No. 12766 and dated August 30, 1975, at 6:20 a.m.

A routine No. 4 Check, Visit No. 1, and No. 4 Check, Visit No. 2 were completed on August 28, 1975. A review of the completed check forms and associated paperwork revealed no significant findings.

4. Airworthiness Directives Compliance and Required Reports

A review of the Airworthiness Directives was accomplished and all applicable AD's were recorded and complied with.

Service Difficulty Reports submitted on N4904 for 1974 and 1975 revealed no significant problems.

Mechanical Interruption Summary Reports for 1975 were reviewed and no significant findings were noted.

LEGEND

1. Empennage and Rear Fuselage
2. Part of Rear Fuselage, Airstairs
3. Center Section
4. Right Wing, Nacelle, and Right Engine
5. Left Wing Center Section
6. Left Nacelle, Engine, and Propeller
7. Left Outer Wing
8. Forward Fuselage and Cockpit Area
9. Right Main Landing Gear Drag Strut
10. Right Engine Propeller
11. Battery
12. Left Outboard Flap
13. Dotted Circle Area - Floor Beams, Floor Boards, Insulated Ducts, Pieces of Wing Leading Edges, Lower Fuselage Structure, Conduits, Combustion Heater Components, Inverter, Engine C7 Tubes
14. Section of Right Outboard Wing and Aileron
15. Nose Wheel and Fork
16. Left Main Landing Gear Actuator
17. Left Main Landing Gear Drag Strut
18. Lower Section of Tail Cone
19. Impact Mark
20. Impact Mark
21. Left Propeller Blade
22. Left Main Landing Gear Tire and Wheel Assembly
23. One-Foot Indentation in Ground, Small Pieces of Red Glass
24. Right Main Landing Gear Bogey
25. Gyrosyn Amplifier

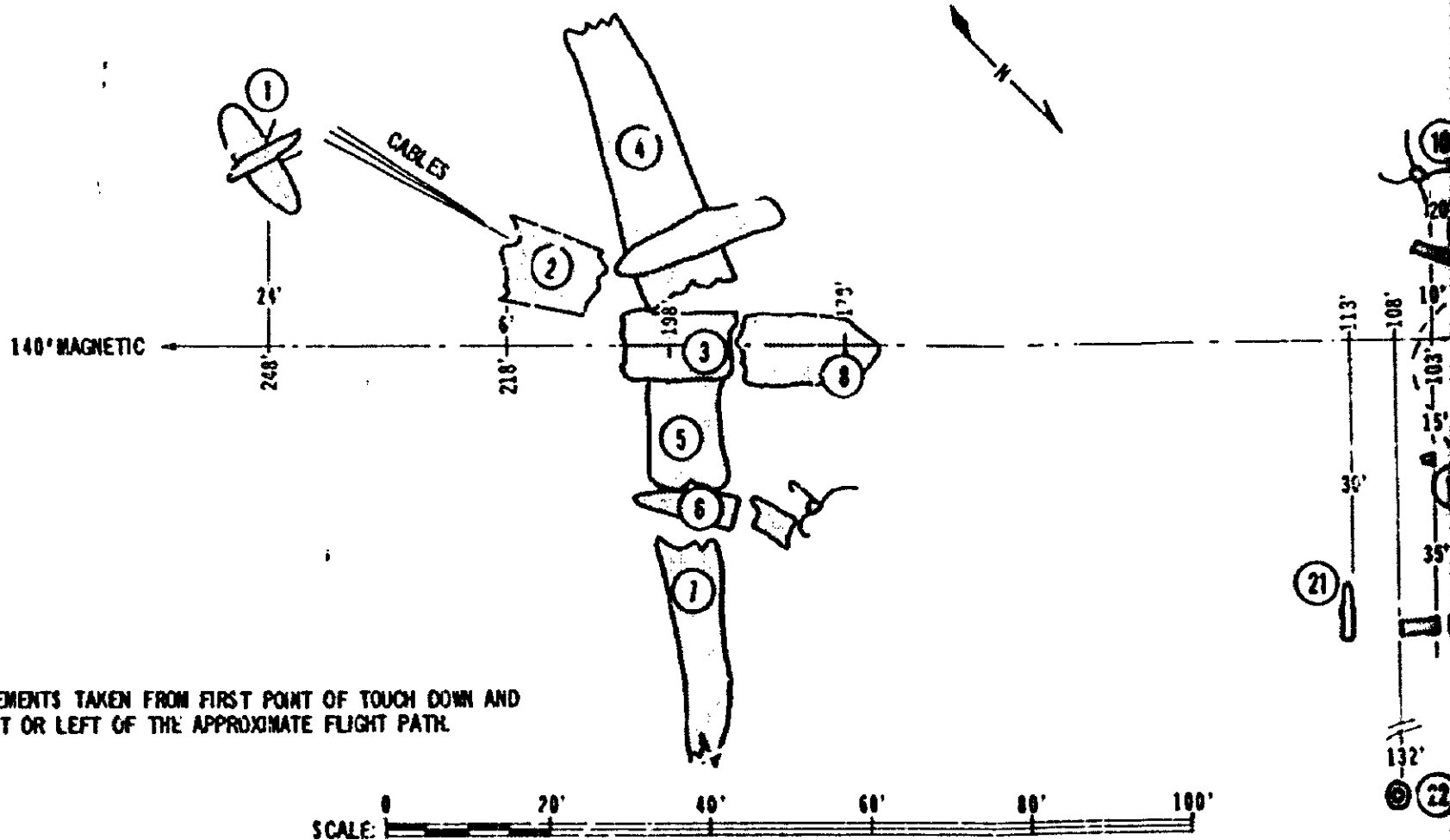
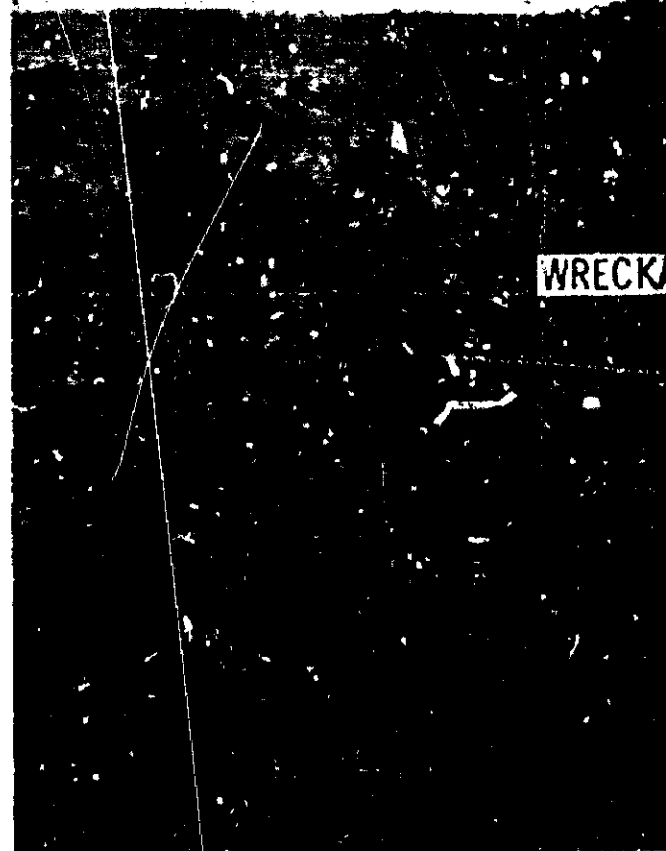



24-B

# BERING

WRECKAGE AREA

INITIAL IMPACT

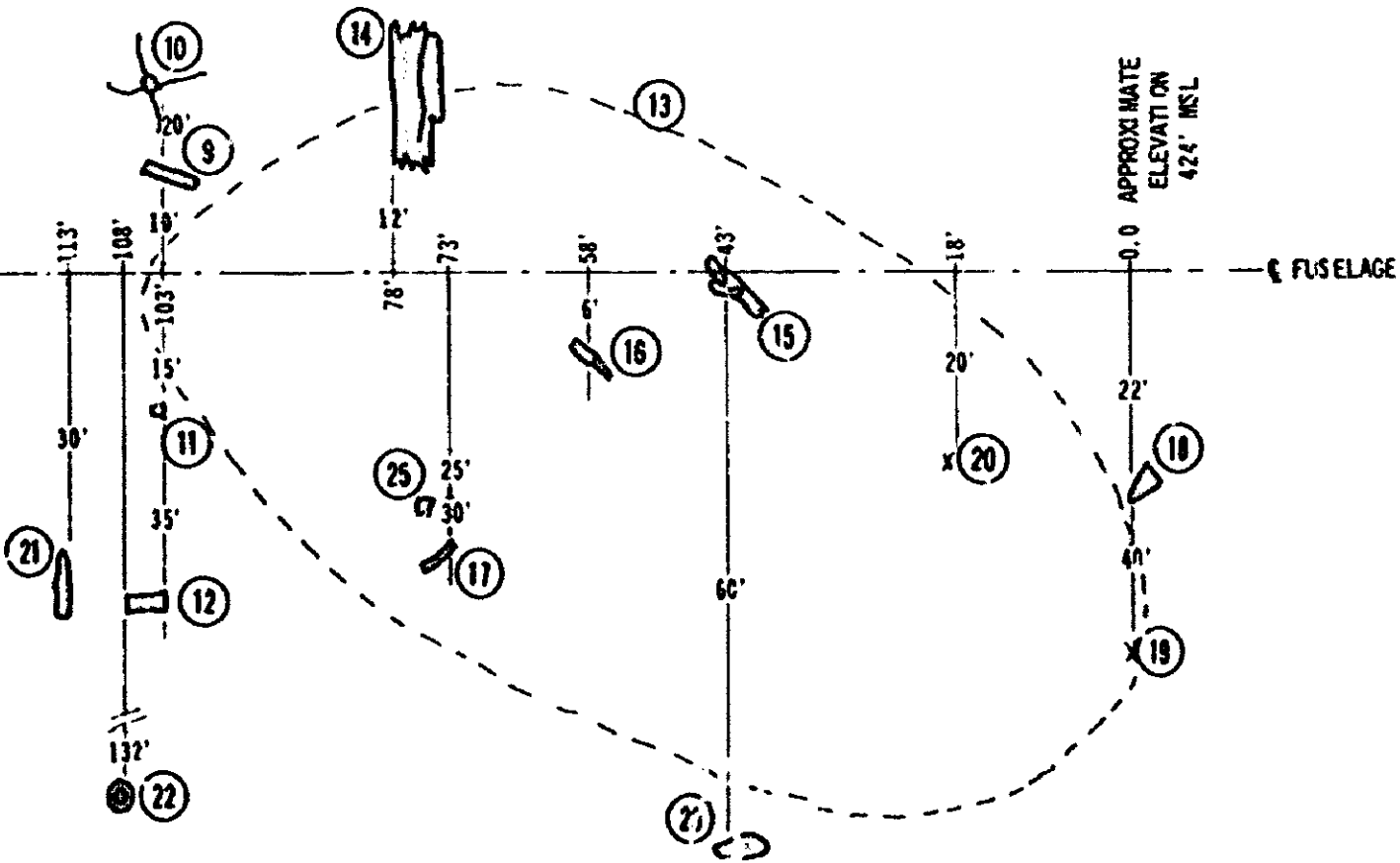
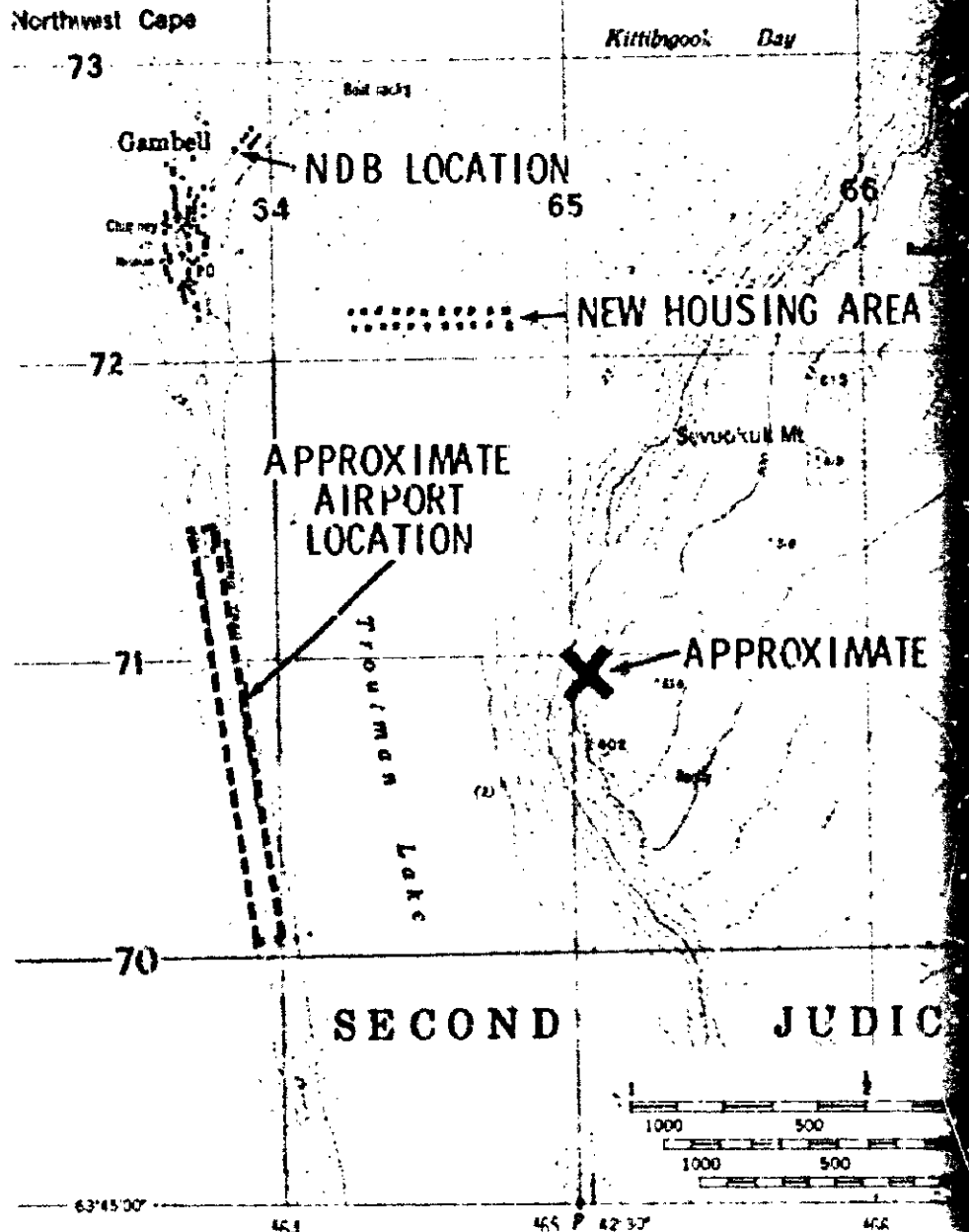

NAT

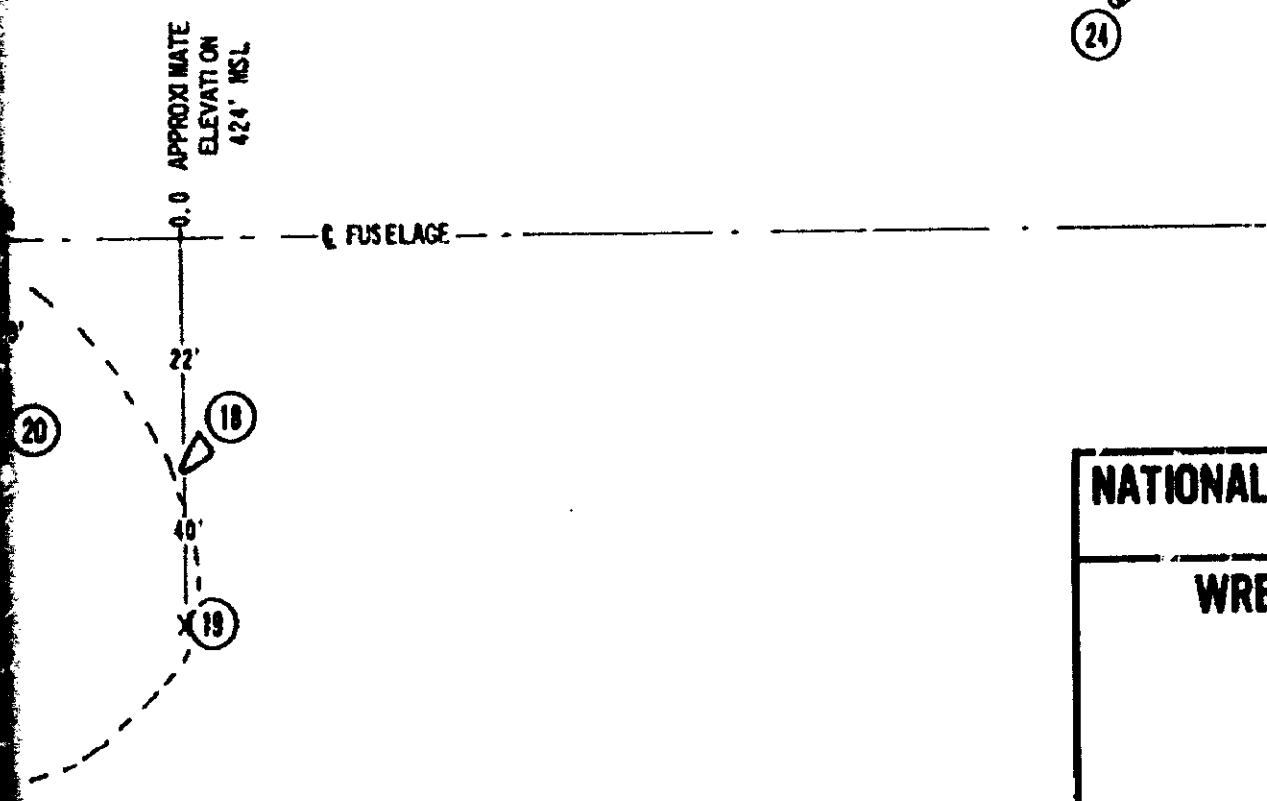
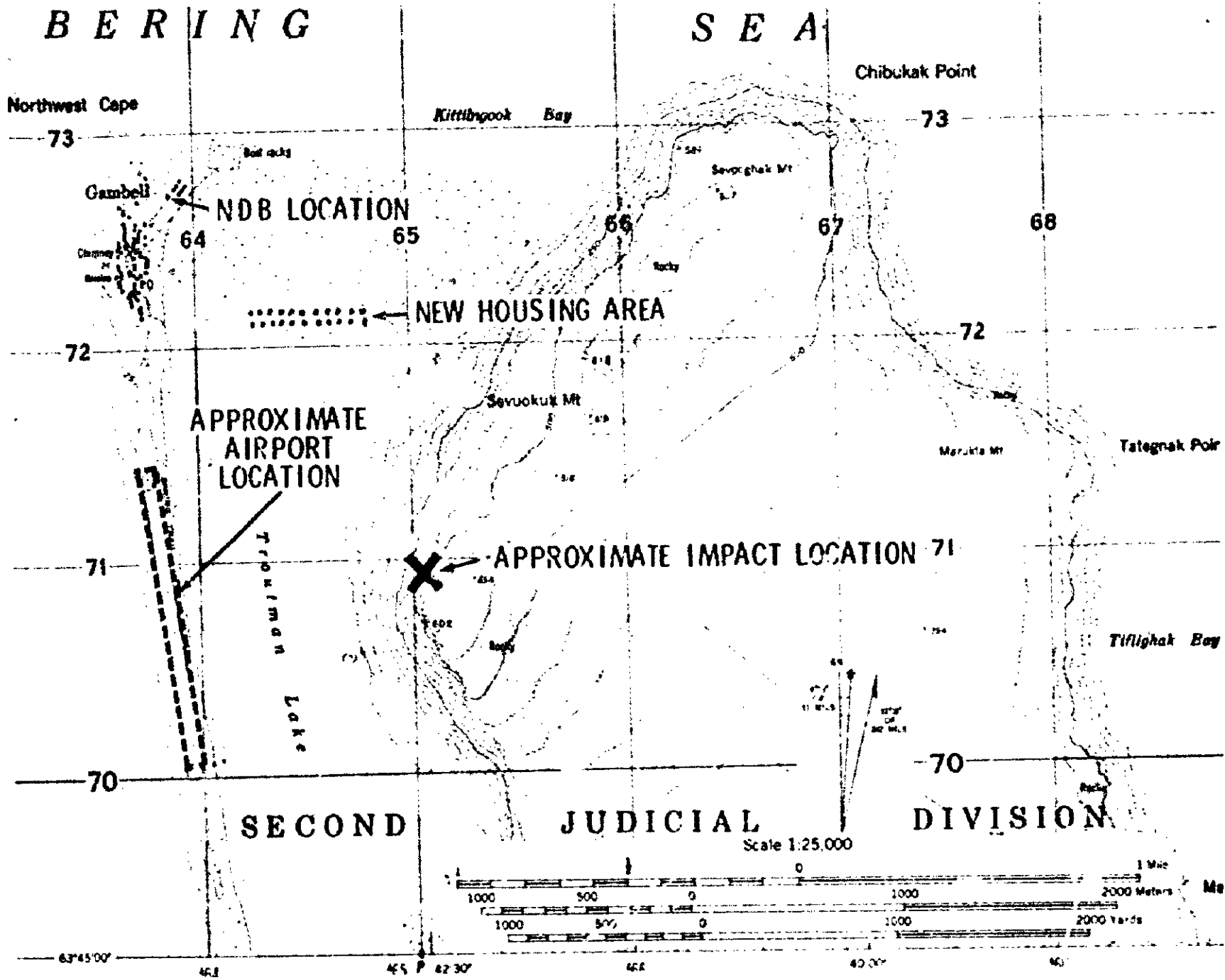

**NATIONAL TRANSPORTATION SAFETY BOARD**  
 WASHINGTON, D.C.

**WRECKAGE DISTRIBUTION CHART**  
**WIEN AIR ALASKA, INC.**  
**FAIRCHILD F-27B, N4904**  
**GAMBELL, ALASKA**  
**AUGUST 30, 1973**

26 - A

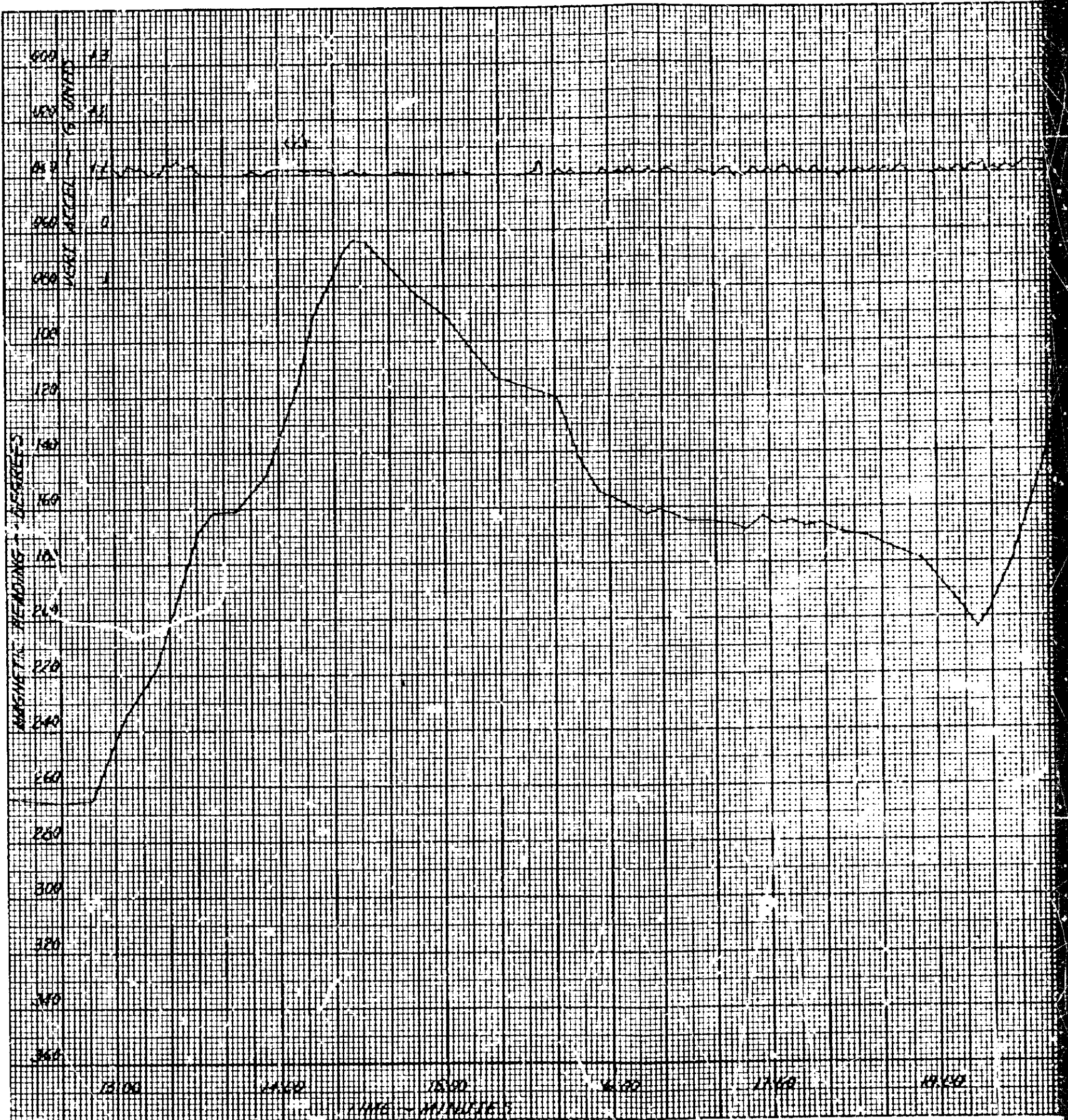



26-8

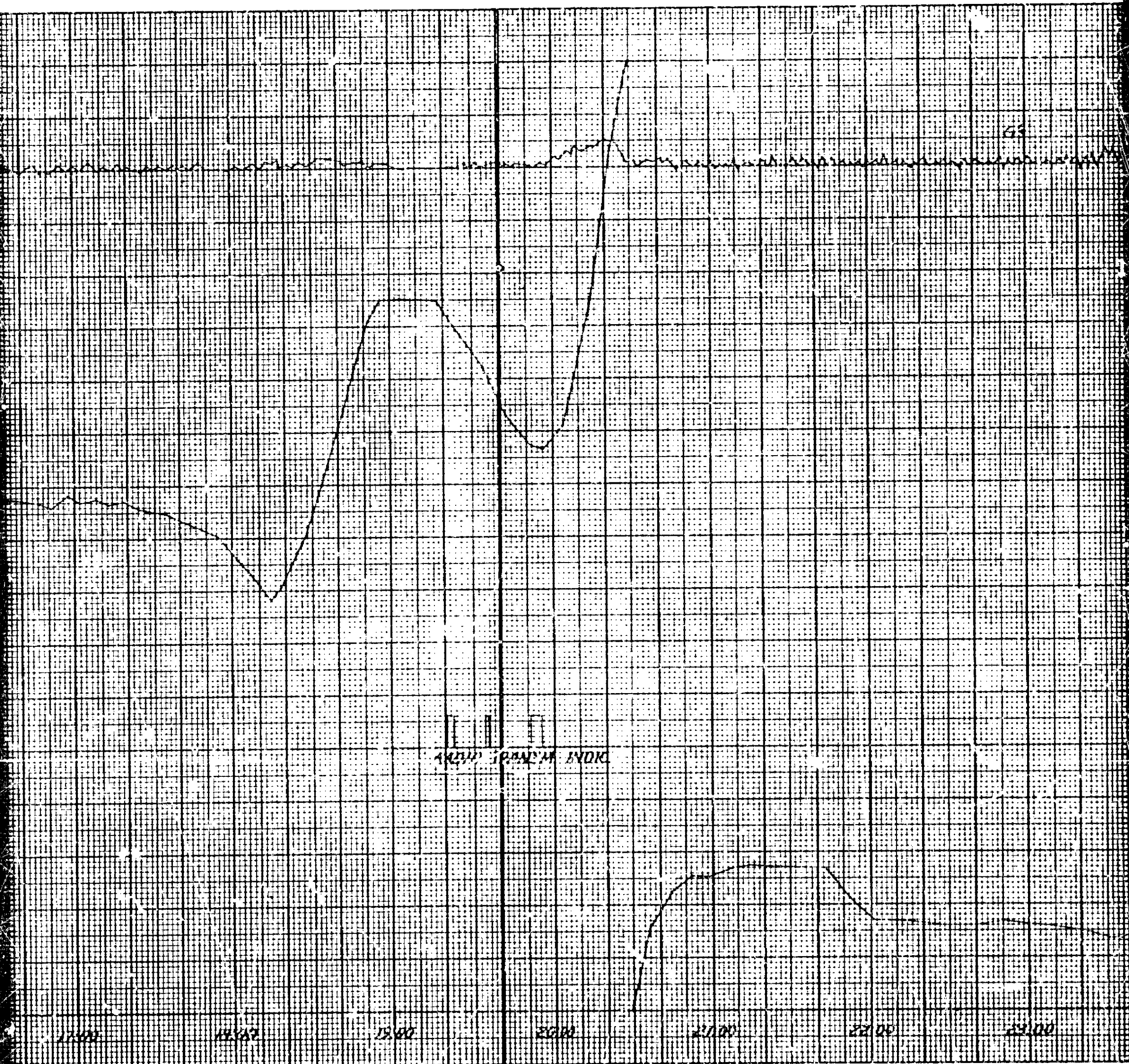

ARTIO IPANAM INDR

17:00

18:00

19:00

20:00

21:00

22:00

23:00

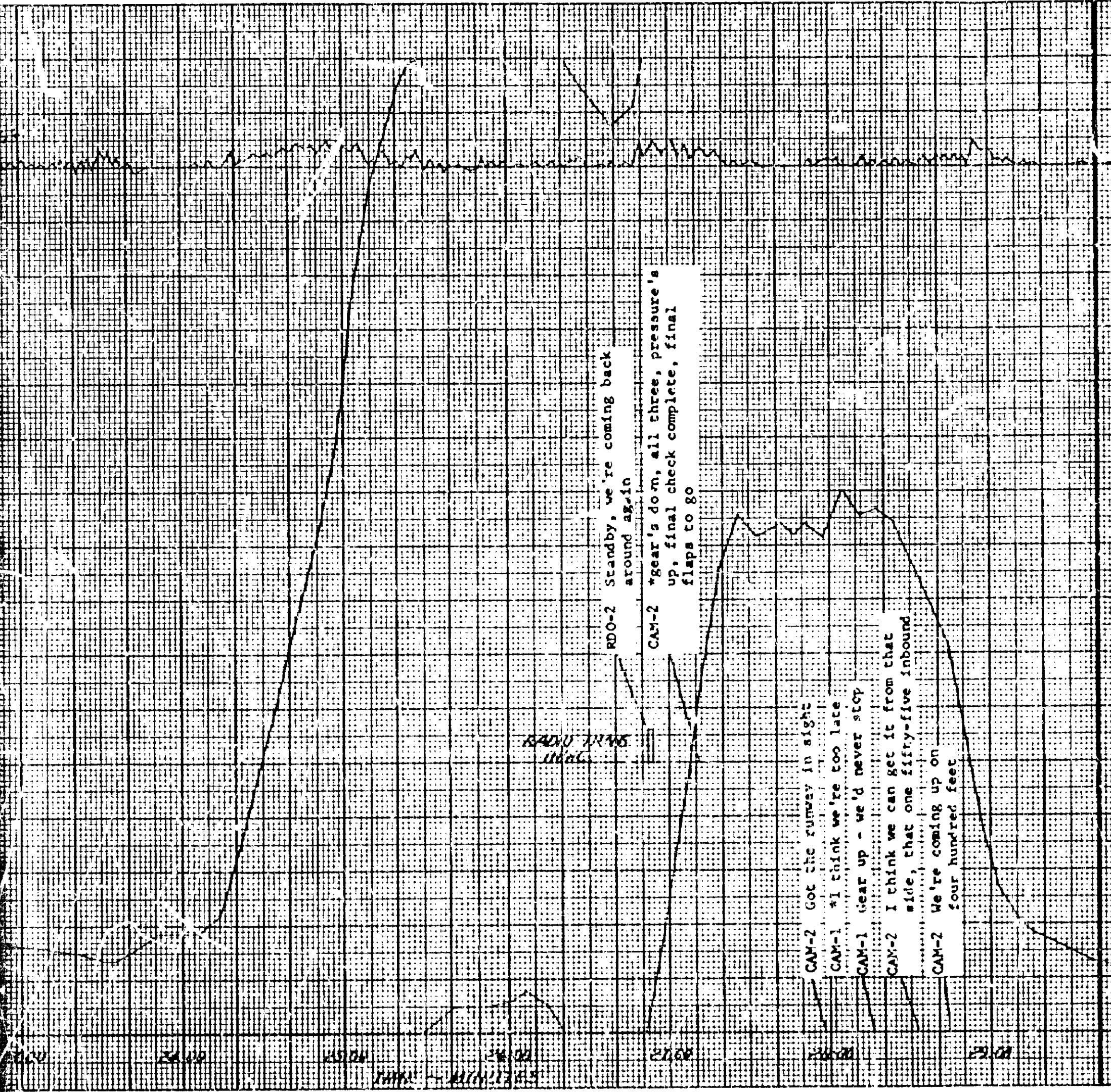

RADIO TRANSMITTER

RDO-2 Standby, we're coming back around again

CAM-2 \*gear's down, all three, pressure's up, final check complete, final flaps to 80

CAM-2 Got the runway in sight

CAM-1 I think we're too late

CAM-1 Gear up - we'd never stop

CAM-2 I think we can get it from that side, that one fifty-five inbound

CAM-2 We're coming up on four hundred feet

0:00

0:10

0:20

0:30

0:40

0:50

1:00





APPENDIX F

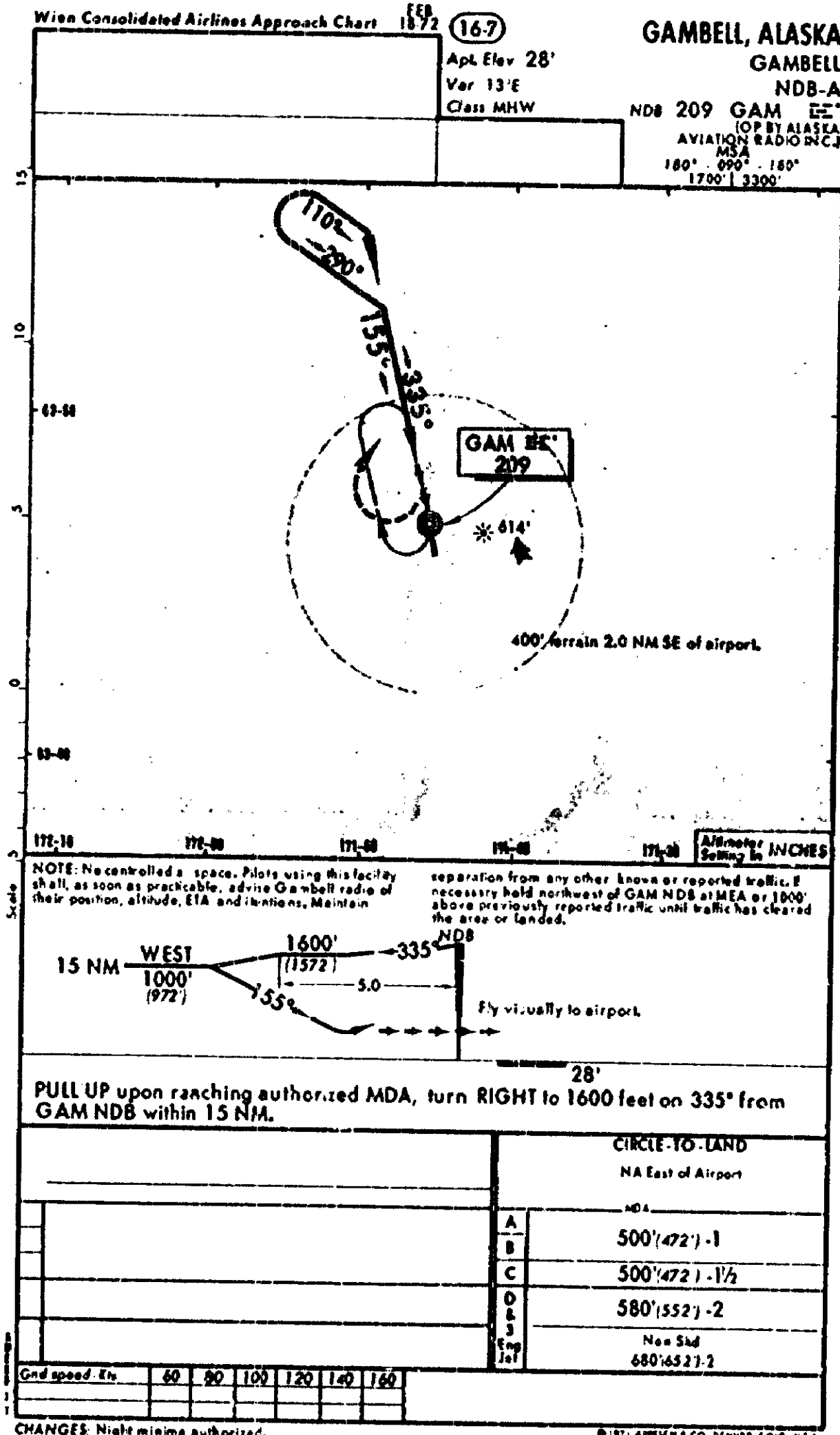

"ILLUSTRATION ONLY - NOT TO BE USED FOR NAVIGATIONAL PURPOSES"

APPENDIX F

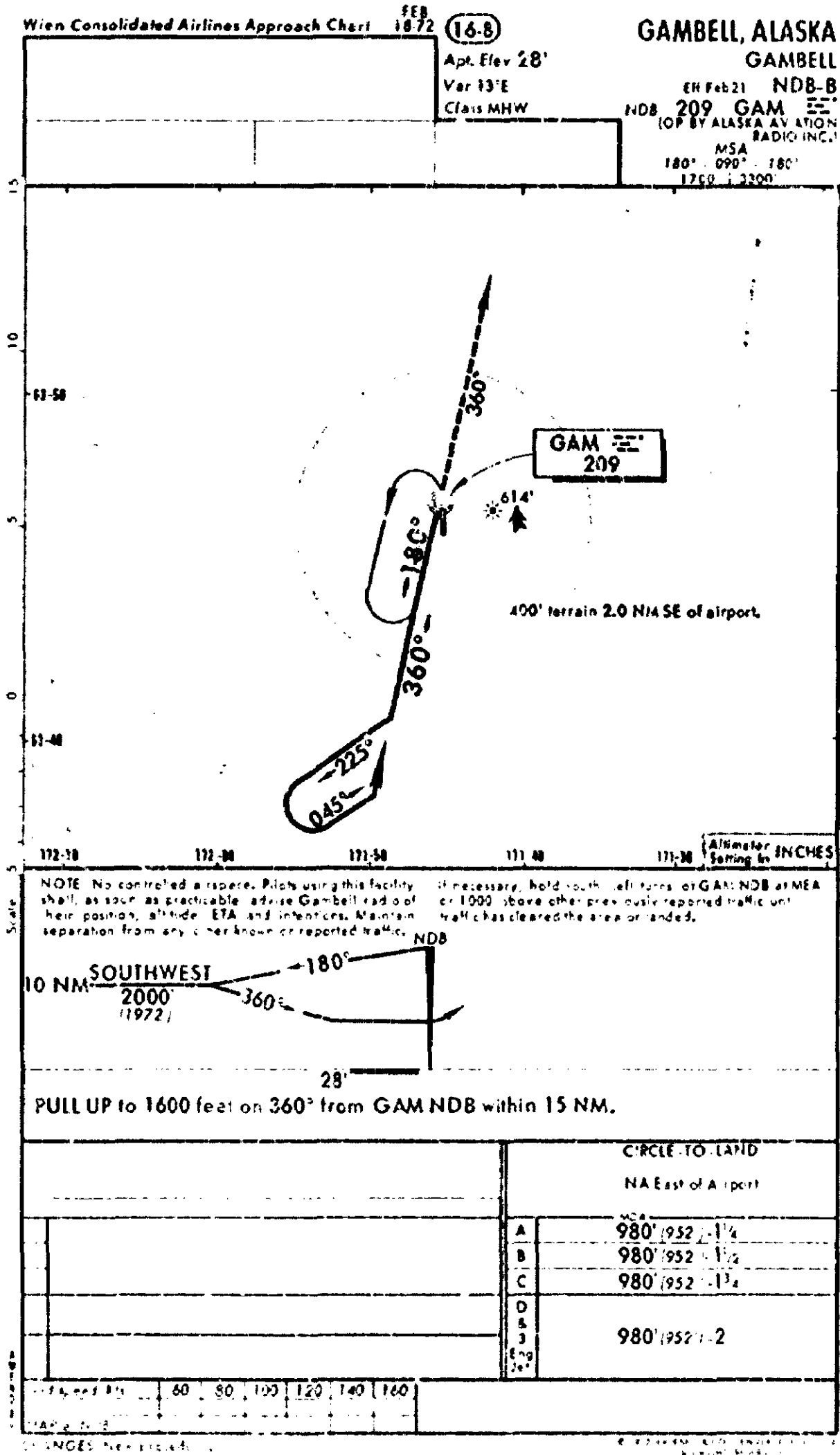

"ILLUSTRATION ONLY - NOT TO BE USED FOR NAVIGATIONAL PURPOSES"



APPENDIX G  
TRANSCRIPTION OF COCKPIT VOICE RECORDING  
WIEN AIR ALASKA F-27B, N4904, FLIGHT 99  
GAMBELL, ALASKA  
AUGUST 30, 1975

LEGEND

CAM	Cockpit area microphone voice or sound source
RDO	Radio transmission from Flight 99 or public address
-1	Voice identified as Captain
-2	Voice identified as First Officer
-?	Voice unidentified
CR-1	Company radio at Savoonga
CR-2	Company radio at Gambell
*	Unintelligible
#	Nonpertinent word
%	Break in continue
( )	Questionable text
(( ))	Editorial insertion
UNK	Unknown
---	Pause

TIME &  
SOURCE

CONTENT

0003	
RDO-2	Fifteen minutes to Gambell
0008	
CR-1	I need your off time from here
0011	
RDO-2	Uh the on times there?
0013	
CR-1	Yeah, on times I mean uh what's your off time? I didn't get it
0021	
RDO-2	Off times were two five, two seven, fifteen minutes to Gambell
RDO-2	Our on times were zero six and zero nine at Savoonga
0033	
CR-1	Uh, roger, you're off at two five, two seven, estimating Gambell at one --- fifteen minutes, I got your on times, already

APPENDIX G

<u>TIME &amp; SOURCE</u>	<u>CONTENT</u>
0042 RDO-2	Okay, thank you
0045 CAM-1	Hang up now
0048 CAM-1	((Sound of laughter))
0051 CAM-2	Okay, say good night, Alice
CAM-1	Gooi night Alice
0104 CAM-2	I guess they think --- they turned the beacon off already
CAM-1	Beacon back on
0112 CAM-1	How about Gambell's beacon *
CAM-2	When we get some altitude we'll call them
0119 RDO	((Sound of ADF identifier GAM))
CAM-2	It's on
CAM-1	It's on? Good
CAM-1	Gambell --- is it *
CAM-2	Mine's on
CAM-1	It's on
CAM	((Clicks simultaneous with above))
CAM-1	Tell them it's on
0226 RDO-2	Wien Gambell, Wien ninety-nine
0236 CAM-1	I'll tell you what we'll do, we'll pick up that # here, bring it to Nome, then back to Savoonga

APPENDIX C

TIME &  
SOURCE

CONTENT

0246  
CAM ((Nonpertinent conversation about cargo))

0300  
CR-2 Ninety-nine, Wien \* \*

0303  
RDO-2 Roger, should be there in about another twelve minutes, uh  
could you give me your weather, please

0308  
CR-2 Roger, Roger, stand by

0439  
CR-2 Ninety-nine, Wien Gambell

0442  
RDO-2 Ninety-nine go ahead

0445  
CR-2 Roger cur current weather is partial obscured sky, visibility  
one to one and a half miles, (just a minute) \* one mile to  
half mile with and fog, temperature is forty-seven, wind is  
calm, altimeter two nine seven zero

0520  
CAM-2 Wind calm?

0522  
CAM-1 Mile and a half mile she said?

CAM ((Sound of laughter))

0525  
CAM-2 I thought she said a mile to a mile and a half

0526  
CAM-1 Huh?

0528  
CAM-2 The first time she said a mile to a mile and a half

CAM-1 Oh, did she?

CAM-2 And then she gave me a mile to a half mile

0531  
CAM-1 I thought she said a half mile --- it's hard to tell

APPENDIX G

TIME &  
SOURCE

CONTENT

CAM-1 Anyway, we're going anyway

CAM-1 Call them

0537

RDO-2 Understand uh the visibility a mile to a mile and a half?

0542

CR-2 Roger, roger. Sometimes about five miles, it's very hard to tell \* \*

0549

CAM-1 ((Nonpertinent conversation about three-wheel hondas to be picked up))

0624

CAM-1 Looks like we got fog hanging in there. That's what the problem is

0633

CAM-1 We'll take a shot from this way and if we can't make it we'll come around and hit it from that side. If we can't make it from there, we'll turn out and (come in underneath it).

0645

CAM-2 If we can't make it that way, we'll go into a hover \* \*

0654

CAM-1 We got low fog in here --- that's what it is \* \*

CAM-2 Yeah

0700

CAM-2 It was up on top of the hill this morning --- probably just moved down the hill

0704

CAM-1 \* \* up the hill down below it

0714

CAM-2 I (don't) think we can make it this away

CAM-1 Read the checklist

APPENDIX G

<u>TIME &amp; SOURCE</u>	<u>CONTENT</u>
0728 CAM	((Approach checklist read))
0820 CAM-1	I'll tell you what I'll do --- just head out this way and go around and intercept the uh the three three five radial back in
0834 CAM-2	We could land up on the hill there and toss the stuff down the hill to them
0838 CAM-1	Could do that
0841 CAM-1	That's where they need the airport --- up on top of the hill
CAM-2	Yeah
0953 CAM-1	That # # near on the ground
CAM-2	What?
0957 CAM-1	Stuff's darn near right on the ground
1028 CAM-?	(Going down)
1045 CAM	((Sound of power reduction))
CAM-?	* *
1155 CAM-2	Which way you comin' in from?
1156 CAM-1	Huh?
1157 CAM-2	What way you going to come in from?
1200 CAM-1	Well we'll take a look at it this way, then ah then take a look at it coming in from the other way

APPENDIX G

<u>TIME &amp; SOURCE</u>	<u>CONTENT</u>
1211 CAM-?	(Not even) * *
1218 CAM-1	Trouble is, the beacon's down town
1221 CAM-1	Have to stay off to the right
1221 CAM-2	One fifty-five inbound?
1241 CAM-?	(I'm ready for the checklist right now)
CAM	((Sound of power reduction))
1254 CAM-1	Put the gear down anyway
1303 CAM-2	* *
1307 CAM-1	Sixteen flaps and final check
1313 CAM	((Sound of gear extending))
CAM-1	(Interception)
CAM-2	* *
1330 CAM-2	Over the water
1338 CAM-1	Over the shoreline, now
1340 CAM-2	We are?
CAM-1	Yeah
CAM	((Sound of additional power reduction))
CAM-?	* *

APPENDIX G

<u>TIME &amp; SOURCE</u>	<u>CONTENT</u>
1348 CAM-1	No, I can't see it from here
CAM-2	* *
1408 CAM-2	The beacon's on the end of the runway
1410 CAM-1	* * at the end of the runway
1417 CAM-1	Can't get much more lined up
1435 CAM-1	Okay, we passed over it. Yeah
1438 CAM-1	Raise the gear
1444 CAM	((Sound of gear retraction))
1500 CAM-?	* * flaps *
1516 CAM-1	If we can't do it IFR, we'll do it VFR
1659 CR-2	Flight ninety-nine, Wien Gambell
1702 RDO-2	Roger ninety-nine, we're going to try it again there
1706 CR-2	Roger, roger. Estimated time was supposed to be zero five or one five?
1715 RDO-2	What did you say?

APPENDIX G

TIME &  
SOURCE

CONTENT

1718  
CR-2 Roger, we're having lots of trouble with our transmitter and I didn't think I had your on --- estimated time to Gambell right. I have it one five, was it supposed to be four five?

1732  
RDO-2 No, it was supposed to be fifteen minutes, but we're going to be awhile. We're coming around now to try it again

1738  
CR-2 Roger, roger \* \*

CAM ((Gambell ADF identifier heard in background))

CAM (( \*\* unidentified noise or possible voice ))

1820  
CAM-? \* \*

1858  
CAM-1 There's the point over there

2028  
CAM-? I think we'll be all right

2104  
CAM-2 Final checklist still complete except for the gear and flaps

2108  
CAM-1 Okay

2122  
CAM-? (All right) \* \*

CAM-? \* \*

2136  
CAM-1 Four hundred feet

CAM-? \* \*

2149  
CAM-? \* \* take a look

2211  
CAM-2 \* \* want to try it again?



APPENDIX G

<u>TIME &amp; SOURCE</u>	<u>CONTENT</u>
2213 CAM-1	Huh?
2214 CAM-2	(Going to try it again from around this way, or you going to try again from this way here)
2218 CAM-1	If I can get that beach line, we'll have it made
2225 CAM-?	* *
CAM	((Sound of windshield wipers activating))
2302 CAM-1	Watch for the beach
CAM-2	Yeah
2307 CAM-2	As soon as I see it, I'll let you know
CAM-?	Huh?
CAM-2	As soon as I see it, I'll let you know
2314 CAM-1	(Okay, I've got it here)
CAM-?	* *
2346 CAM-1	There's the # runway right there
CAM-?	Try it again
2359 CAM-2	Okay, I've got the village from here
2403 CAM-1	Yeah, I've got the runway
2410 CAM-1	Sixteen flaps
2435 CAM-1	Gear down

APPENDIX G

<u>TIME &amp; SOURCE</u>	<u>CONTENT</u>
2436 CR-2	Ninety-nine, Wien Gambell
2441 RDO-2	Standby, we're coming back around again
2443 CR-2	Roger, roger
2445 CAM-1	Twenty seven
2449 CAM	((Sound of gear warning horn))
2500 CAM-2	* gear's down, all three, pressure's up, final check complete, final flaps to go
2508 CAM-1	Twenty-seven
2510 CAM-2	You're at twenty-seven
2529 CAM-2	One ten
CAM	((Sound of power reduction))
2544 CAM-2	Hundred feet
2546 CAM-1	Full flaps
2547 CAM-2	Got the runway in sight
CAM-1	Yeah
CAM	((Sound of laughter))

APPENDIX G

<u>TIME &amp; SOURCE</u>	<u>CONTENT</u>
2551 CAM-1	* I think we're too late
2552 CAM-2	* flaps up?
2554 CAM-1	Yeah, flaps sixteen
2555 CAM-2	Flaps coming to sixteen
2558 CAM-2	Positive rate
CAM	((Sound of power increase))
2605 CAM-1	Gear up
CAM	((Sound of gear retraction))
CAM-1	We'd never stop
CAM-2	What?
2607 CAM-1	We might have stopped
CAM-?	(Off) the end of the runway
2617 CAM-2	Think we can get it from that side
2620 CAM-1	Huh?
2622 CAM-2	I think we can get it from that side that one fifty-five inbound
2633 CAM-2	We're coming up on four hundred feet
2638 CAM-1	Flaps up

APPENDIX G

<u>TIME &amp; SOURCE</u>	<u>CONTENT</u>
2643 CAM-1	# hard to see, I'll tell you
2651 CAM-2	I think that one fifty-five inbound is the better way to go
2655 CAM-2	At least we saw the runway that time
CAM-1	Huh?
2658 CAM-2	At least we saw the runway that time
2709 CAM-2	(I can turn them on in just a second here)
2713 CAM-1	Just keep them in auto --- that's all right
2750 CAM	((Sound of power reduction))
2812 CAM-2	One fifty-five heading inbound * * perfect * *
2844 CAM-2	Okay, we're over the beacon
2847 CAM-1	Beacon right now, final flaps, gear down
2848 CAM	((Sound of gear warning horn))
CAM	((Sound of gear extending))
2851 CAM-2	Youre a little fast
2853 CAM-1	Yeah, I know
2855 CAM-2	* (going down)
2908 CAM	((Click))
2909 CAM	((High pitched whistle for one second))

APPENDIX G

TIME &  
SOURCE

CONTENT

CAM-?	* *
2914	
CAM-?	((Exclamation))
2915	
CAM	((Sound of impact))

APPENDIX H

TABULATION OF FLIGHT DATA RECORDER PARAMETERS  
FOR LAST PORTION OF FLIGHT

1	2		3	4		5		6	7	8
	MIN.	SECS.				MSL ALTD FEET	TRUE AIRSP KNOTS			
9	57.200	1287.70	219.14	275.00		15	16.800	619.92	123.63	181.93
9	57.000	1230.75	218.90	275.00		15	17.400	619.06	124.12	181.79
10	12.600	1083.87	219.02	277.78		15	18.600	608.03	125.06	182.18
10	12.400	1035.38	214.70	277.97		15	21.600	613.92	130.07	182.45
10	14.000	977.20	215.65	278.50		15	24.600	625.49	135.10	183.11
10	24.000	656.34	214.87	278.81		15	25.800	623.83	136.60	183.33
10	31.800	436.90	214.12	278.30		15	26.400	622.51	137.04	183.57
10	33.600	427.11	213.78	278.93		15	34.200	601.25	145.57	187.05
10	37.800	335.11	213.05	278.52		15	34.800	596.37	146.26	187.31
10	42.400	310.51	210.37	278.06		15	40.800	600.87	149.21	189.99
10	43.200	317.88	210.07	278.00		15	41.400	613.73	149.51	190.28
10	48.000	276.76	207.85	270.80		15	45.200	661.74	147.71	192.40
10	54.600	193.16	198.90	260.90		15	52.200	921.73	145.47	199.25
10	56.400	186.72	196.36	258.70		15	52.800	916.54	145.22	199.71
11	6.000	1073.89	184.08	232.51		15	54.400	947.01	147.37	203.70
11	6.800	1059.66	183.25	230.90		15	58.200	948.05	148.61	205.70
11	10.200	1030.30	181.40	220.44		16	6.000	952.56	152.95	212.23
11	16.200	981.37	178.32	203.00		16	6.600	952.92	153.29	216.51
11	16.400	974.48	178.01	201.78		16	8.400	994.42	154.42	214.45
11	20.400	931.27	175.06	183.57		16	10.800	1023.57	153.99	211.70
11	22.800	924.32	173.14	181.90		16	13.200	1052.40	153.56	204.44
11	26.400	923.90	170.34	176.90		16	15.600	1052.86	153.05	201.19
11	27.000	921.53	169.73	176.07		16	19.200	1075.47	153.94	193.30
11	28.200	930.73	168.56	174.40		16	21.600	1090.53	154.52	185.70
11	36.600	994.97	160.17	174.20		16	25.800	1104.79	155.52	172.43
11	37.800	1004.14	158.97	172.76		16	33.000	1127.88	157.24	149.34
11	39.000	1014.34	158.15	171.33		16	34.200	1134.71	157.74	145.50
11	46.200	1053.77	153.05	162.72		16	38.400	1150.57	159.45	130.41
11	46.800	1053.97	152.38	162.00		16	43.200	1133.11	161.29	113.16
11	54.000	1056.42	144.47	143.92		16	43.800	1131.25	161.59	111.00
11	55.800	1030.12	142.44	136.90		16	48.000	1119.23	163.76	103.00
11	58.200	1017.46	141.40	130.20		16	49.800	1112.45	164.70	102.89
12	0.0	1007.79	140.63	123.40		16	52.800	1150.31	166.37	102.71
12	4.200	945.45	138.83	107.43		16	55.200	1163.52	166.53	102.57
12	5.400	943.08	139.20	103.00		16	56.400	1171.66	166.61	102.53
12	9.600	955.40	140.41	93.72		17	2.000	1209.65	167.02	102.64
12	10.400	937.69	140.73	90.51		17	3.000	1216.42	167.10	102.90
12	15.000	901.09	143.82	80.80		17	10.200	1265.28	167.61	103.50
12	16.200	864.17	144.91	76.40		17	10.800	1259.36	167.66	104.45
12	21.400	743.10	148.67	75.95		17	12.000	1283.71	168.15	106.34
12	22.800	745.81	149.58	73.12		17	25.200	1263.16	173.15	123.30
12	24.000	834.13	149.34	77.30		17	26.400	1256.68	173.59	129.20
12	28.200	733.24	149.62	81.81		17	32.000	1226.55	175.65	142.50
12	33.600	744.28	147.68	87.60		17	33.600	1217.94	176.24	146.30
12	40.200	693.33	146.53	93.43		17	37.200	1198.59	177.57	150.58
12	40.800	692.08	146.44	94.40		17	38.400	1194.91	177.54	152.00
12	42.000	689.57	146.25	95.31		17	43.200	1184.49	177.54	157.96
12	52.200	650.11	143.09	103.00		17	45.000	1172.39	176.72	158.49
12	54.000	643.15	142.54	105.25		17	48.000	1186.58	174.92	159.80
12	59.400	622.26	140.87	112.03		17	51.600	1203.58	172.54	155.49
13	10.400	578.15	137.35	126.30		17	56.400	1242.63	168.25	150.90
13	17.400	552.62	135.32	128.44		18	0.600	1276.79	164.50	135.23
13	18.600	531.29	134.92	128.83		18	4.200	1306.07	161.28	115.88
13	26.400	455.22	137.37	131.36		18	5.400	1294.51	160.15	109.44
13	27.600	485.24	137.83	131.74		18	6.600	1297.18	159.71	103.00
13	32.400	485.73	129.37	133.30		18	8.400	1298.15	159.04	87.85
13	37.200	486.13	120.91	145.70		18	13.200	1273.04	157.21	47.50
13	37.800	473.68	119.83	147.25		18	20.400	1235.35	154.45	17.50
13	38.000	473.41	119.80	147.77		18	21.600	1185.12	154.93	12.50
13	40.400	469.54	119.45	155.00		18	24.600	1059.50	158.04	358.32
13	43.200	466.30	119.14	159.13		18	27.600	975.45	160.03	344.14
13	48.000	435.84	118.48	167.40		18	28.200	954.51	160.82	341.53
13	57.400	374.89	117.17	171.48		18	34.800	748.71	169.43	330.77
13	58.200	369.69	116.95	171.84		18	36.600	670.12	170.23	327.90
14	6.600	404.56	114.08	175.40		18	37.200	644.09	170.50	327.45
14	7.200	411.53	113.47	175.34		18	42.000	628.69	173.12	323.88
14	9.000	411.84	113.75	174.45		18	44.400	590.80	172.44	322.10
14	11.400	404.75	112.28	174.73		18	45.600	571.84	172.09	322.18
14	20.400	401.85	107.75	177.95		18	50.400	528.01	170.50	322.50
14	28.000	403.72	107.69	178.20		18	58.000	458.54	168.74	320.04
14	30.000	431.69	106.94	178.20		18	60.000	440.28	168.20	319.39
14	31.400	437.27	105.79	178.47		19	0.600	431.41	168.03	319.20
14	32.400	440.55	106.49	178.56		19	6.600	342.71	166.33	317.90
14	35.000	444.41	107.29	178.96		19	12.000	262.88	164.89	314.11
14	36.400	446.60	107.54	179.20		19	16.200	227.47	163.69	318.27
14	42.400	455.73	108.46	181.20		19	27.000	136.57	160.70	318.70
14	45.000	459.27	108.83	179.47		19	33.600	135.62	159.00	318.95
14	47.400	459.27	108.83	178.03		19	34.800	135.73	158.70	319.20
14	49.400	470.78	108.84	176.40		19	43.800	136.67	154.42	311.00
14	54.000	490.92	108.87	178.40		19	52.800	137.58	154.15	333.20
14	58.400	513.92	108.91	178.32		20	6.000	134.94	150.82	334.50
14	60.000	529.48	109.91	178.22		20	7.200	139.07	140.52	339.40
15	0.0	529.34	109.91	178.20		20	9.000	135.20	150.05	339.76
15	3.000	570.12	112.39	174.65		20	19.800	121.98	147.94	340.70
15	4.400	565.22	113.84	180.20		20	27.000	113.34	144.53	340.70
15	9.400	557.07	117.69	173.24		20	28.000	113.33	144.43	340.70
15	10.400	562.36	118.64	173.00						

LEGEND

- 1--Elapsed time adjusted to CDT time base.
- 2--Computed pressure altitude corrected to MSL.
- 3--Calculated true airspeed based on manufacturer's calibration data for reversed FDR pressure input to airspeed sensor.
- 4--True heading corrected for magnetic variation.

APPENDIX H

MIN.	SECS.	MSL ALTD FEET	TRUE AIRSP KNOTS	TRUE WINDG DEGS	MIN.	SECS.	MSL ALTD FEET	TRUE AIRSP KNOTS	TRUE WINDG DEGS
20	35.600	113.81	146.19	340.70	25	3.600	281.76	129.59	245.20
20	40.900	115.71	145.22	339.63	25	11.600	192.69	120.56	200.90
20	42.000	119.79	145.12	339.50	25	15.600	145.00	118.94	188.41
20	57.000	170.56	143.79	341.23	25	17.400	152.74	118.29	183.41
20	57.600	169.74	143.72	341.30	25	18.000	150.70	117.59	181.90
20	58.700	169.00	143.67	341.38	25	21.600	138.47	113.49	185.90
21	4.000	191.86	145.41	342.11	25	25.200	153.94	109.60	189.70
21	7.800	204.43	146.53	342.59	25	27.300	160.76	107.37	189.76
21	8.400	215.99	146.75	342.67	25	29.500	185.74	106.69	187.72
21	12.600	232.33	144.45	343.20	25	29.400	190.73	106.56	187.51
21	13.000	236.98	143.60	343.54	25	34.200	191.00	104.85	185.00
21	14.400	243.77	143.82	343.71	25	35.400	191.08	104.43	185.97
21	22.200	261.94	143.84	345.90	25	34.600	197.92	104.70	188.95
21	24.000	277.33	142.80	345.90	25	39.000	173.41	105.25	188.90
21	25.700	256.05	142.85	345.60	25	43.200	131.78	106.06	185.00
21	25.800	260.36	143.92	345.93	25	44.400	119.76	106.31	185.45
21	27.600	339.87	142.50	345.60	25	48.200	81.13	108.24	189.73
21	29.400	319.38	143.87	344.68	25	49.800	66.11	107.38	190.27
21	30.800	475.71	143.20	343.86	25	51.000	36.04	105.68	187.27
21	36.000	541.12	134.32	340.19	25	57.000	20.85	97.39	172.60
21	36.000	541.13	134.32	340.19	25	58.000	18.42	96.00	174.01
21	37.800	530.02	131.92	338.96	25	58.200	17.94	95.73	174.79
21	40.900	515.64	134.03	336.92	26	0.600	46.45	96.17	177.67
21	42.600	600.44	135.25	335.70	26	3.600	22.99	96.62	187.90
21	46.800	634.93	137.12	335.70	26	4.200	18.28	96.73	181.67
21	48.000	649.97	137.30	335.70	26	9.600	25.98	102.75	179.60
21	57.600	720.37	149.60	335.70	26	15.600	36.54	109.45	184.40
21	59.200	737.45	149.20	335.70	26	16.800	36.25	110.79	187.08
21	59.400	757.80	150.39	334.72	26	18.000	57.41	112.16	189.56
22	4.000	800.64	149.57	329.30	26	25.800	175.11	119.44	205.70
22	4.600	804.57	149.50	327.31	26	33.000	249.84	116.71	223.35
22	11.000	768.42	150.78	317.76	26	33.600	257.52	120.77	224.82
22	13.800	778.51	151.60	303.50	26	35.400	291.76	120.49	229.73
22	16.200	759.84	152.30	293.35	26	35.000	300.45	120.70	230.70
22	18.600	751.62	152.98	287.20	26	42.000	387.92	131.74	258.95
22	20.400	736.91	153.49	276.58	26	43.200	361.92	132.24	264.60
22	21.600	723.72	153.82	272.17	26	45.000	323.53	133.02	273.70
22	25.000	698.37	155.74	259.64	26	48.300	329.95	137.20	282.80
22	25.200	698.91	155.85	258.93	26	49.800	340.16	144.16	288.90
22	27.400	666.52	157.17	250.10	26	52.200	349.73	149.73	309.01
22	29.400	643.72	158.16	247.34	26	53.400	381.82	152.54	322.57
22	34.200	572.73	159.99	221.66	26	55.200	376.06	153.32	319.00
22	34.400	556.40	159.73	219.07	26	58.000	411.99	154.47	323.92
22	35.000	558.77	159.28	213.40	26	58.800	416.94	154.80	325.22
22	43.200	569.48	156.58	184.80	27	3.000	402.77	156.64	332.00
22	45.600	573.22	155.68	179.34	27	7.200	567.01	158.40	335.74
22	47.400	579.62	155.61	164.81	27	7.800	576.48	158.50	335.70
22	48.600	581.80	154.40	159.10	27	10.800	613.16	158.58	337.16
22	52.200	588.38	152.57	135.20	27	13.000	631.23	158.62	339.23
22	54.000	591.64	151.66	115.64	27	15.600	637.51	158.64	338.62
22	55.200	573.44	151.00	103.00	27	20.400	733.95	161.86	341.54
23	0.600	543.27	151.75	69.55	27	27.000	778.34	174.99	345.05
23	1.800	520.67	151.88	67.12	27	31.200	798.40	186.36	347.10
23	2.400	511.31	152.09	59.40	27	34.800	816.53	187.55	347.64
23	7.000	440.15	153.68	43.47	27	39.600	897.07	189.27	348.47
23	8.400	418.49	154.16	38.43	27	44.400	935.72	188.16	349.80
23	11.400	376.83	155.50	29.19	27	45.600	945.60	187.88	352.91
23	13.800	339.19	156.57	21.40	27	53.400	579.81	164.12	10.10
23	17.400	282.70	158.18	14.40	27	55.800	99.51	162.96	18.41
23	18.000	273.30	158.44	14.15	27	60.000	900.78	161.75	32.45
23	18.800	335.78	159.45	13.45	28	1.200	887.45	164.81	37.10
23	22.200	360.79	158.57	12.40	28	1.800	881.37	165.33	39.76
23	30.000	442.08	147.22	5.95	28	9.600	694.79	171.90	74.60
23	30.400	450.99	146.65	5.42	28	12.000	637.37	173.92	83.93
23	33.000	440.25	144.25	3.40	28	15.600	551.27	176.93	98.23
23	39.600	410.67	137.68	3.17	28	16.800	541.12	176.92	103.00
23	44.400	392.46	137.63	3.00	28	23.400	485.30	176.77	125.40
23	46.000	397.04	140.29	2.64	28	27.600	449.78	176.69	133.70
23	48.000	379.67	141.11	2.70	28	28.200	439.17	176.25	134.89
23	53.400	181.10	137.66	1.00	28	31.600	417.99	173.80	142.00
23	54.000	181.24	137.28	0.60	28	33.400	407.89	172.58	145.08
23	55.800	166.58	136.09	359.40	28	34.200	408.75	172.44	146.10
23	58.400	158.87	135.46	357.40	28	36.600	386.02	171.79	150.20
24	3.000	348.67	134.54	0.72	28	41.400	340.54	170.49	156.20
24	3.400	346.53	134.44	0.73	28	43.200	323.44	170.01	155.21
24	6.000	344.56	133.94	2.40	28	49.200	314.67	169.51	151.90
24	10.200	341.13	133.04	8.44	28	49.800	313.79	168.37	151.92
24	18.000	334.79	133.08	20.73	28	51.000	279.66	167.23	151.97
24	19.200	364.31	133.10	22.01	28	51.000	299.66	167.23	151.97
24	19.800	355.67	132.83	22.40	28	54.000	408.22	164.76	152.10
24	30.600	393.85	127.95	38.20	28	54.600	429.93	164.25	152.31
24	35.000	405.26	125.98	34.48	28	55.800	490.25	163.30	152.73
24	39.000	415.61	124.14	31.10	28	60.000	556.07	168.02	154.28
24	43.200	426.48	122.25	10.76	29	1.200	574.88	143.65	154.45
24	43.000	414.72	123.42	147.52	29	4.800	499.38	130.20	159.22
24	49.200	384.39	123.87	341.71	29	6.200	456.27	125.78	159.47
24	50.400	370.09	124.97	335.90	29	8.600	451.84	124.45	159.60
24	54.600	313.33	129.52	307.67	29	9.000	434.19	120.61	159.71
24	58.400	349.05	131.57	295.57	29	12.600	407.71	113.27	154.43
24	57.600	334.80	129.80	297.50	29	13.800	383.49	110.97	154.20
24	58.900	324.54	128.04	283.20	29	15.000	359.28	108.67	151.70
25	0.0	312.28	126.27	273.70					
25	1.200	301.03	124.51	264.20					
25	1.800	301.68	124.30	254.45					

END OF READOUT DATA

APPENDIX I

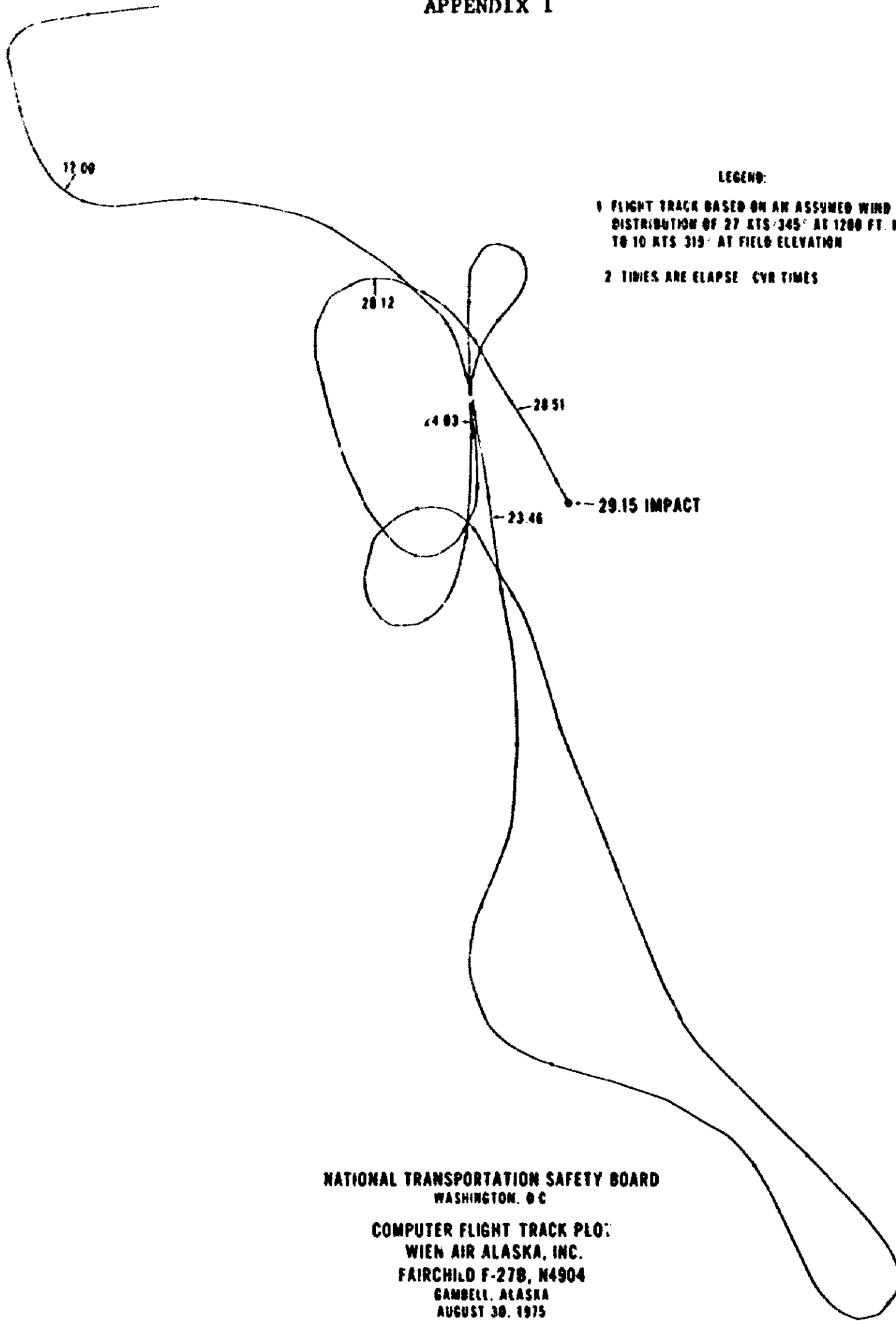

NATIONAL TRANSPORTATION SAFETY BOARD  
WASHINGTON, D C

COMPUTER FLIGHT TRACK PLOT  
WIEN AIR ALASKA, INC.  
FAIRCHILD F-27B, N4904  
GAMBELL, ALASKA  
AUGUST 30, 1975



NATIONAL TRANSPORTATION SAFETY BOARD  
WASHINGTON, D.C.

APPENDIX J

ISSUED: February 8, 1976

-----  
Forwarded to:

Honorable John L. McLucas  
Administrator  
Federal Aviation Administration  
Washington, D. C. 20591  
-----

SAFETY RECOMMENDATION(S)

A-76-1 & 2

On September 30, 1975, Wien Air Alaska Flight 99, a Fairchild F-27B, crashed into a mountain while attempting to land at the village of Gambell on St. Lawrence Island, Alaska. The National Transportation Safety Board's investigation of the crash revealed that certain provisions of 14 CFR 139 are not being complied with. Further, the investigation disclosed that the runway at Gambell as well as those of many other certificated airports in Alaska did not have adequate visual identification markings.

When Flight 99 crashed, the airport's rotating light beacon had not been operating for several days; the failure had been reported to the State of Alaska. Similarly, several runway lights were burned out and some of the runway light supports were bent or otherwise damaged. Moreover, a Notice to Airmen (NOTAM) had not been issued regarding the condition of these lighting systems. The Safety Board believes that the lack of these visual aids, especially the rotating light beacon, may have been a factor in the flightcrew's failure to locate the runway during repeated attempts to land.

The above conditions were permitted to exist, in spite of the provisions of 14 CFR 139.47, 139.57, and 139.87, which specify that airport lighting will be cleaned and replaced as necessary upon self-inspection, and that there must be a reporting system to insure prompt corrective action so that systems are maintained in operable conditions. Further, 14 CFR 139.69 requires that NOTAM's regarding these airport conditions be issued to air carrier users of the airport.

The Safety Board is aware that Gambell and many other certificated airports in Alaska are exempted from various portions of 14 CFR 139 which are considered to be impractical or not in the public interest. However, operation and maintenance of airport lights and the need for the issuance of NOTAM's were not exempted and are not considered impractical to implement or enforce.

APPENDIX J

Honorable John L. McLucas

In addition to the poor condition of the airport lighting, the contrast between the runway at Gambell and its immediate surroundings is poor, especially when visibility is low. There are no runway centerline markings, threshold markings, touchdown zone markings, or other visual markings to aid in distinguishing the runway from surrounding terrain. Runway contrast is further reduced by snow in the winter months. These conditions also exist at other airports in Alaska which are certificated for air carrier operations.

The Safety Board is aware of programs, including those by the State of Alaska, to upgrade airport facilities, such as visual aids. We recognize that there are funding and seasonal logistics problems; however, we believe that some measures should be taken to raise the level of safety at these airports. For instance, runway centerline markings and other identifying markings, such as large wooden panels, brightly colored pylons, and VASI's would increase greatly the conspicuity of the runway environments at Gambell and at other Alaskan airports.

In view of the above, the National Transportation Safety Board recommends that the Federal Aviation Administration:

1. Insure that certificated airports in Alaska comply with the provisions of 14 CFR 139 -- specifically those provisions which require that airport lighting systems and similar equipment be maintained in an operable condition and that NOTAM's be issued regarding the conditions of such items, as needed. (Class II - Priority followup)
2. Expedite existing programs and initiate additional programs to install and improve facilities at certificated airports in Alaska so that the visual conspicuity of runway environments is improved. (Class II - Priority followup)

REED, Acting Chairman, McADAMS, THAYER, BURGESS, and HALEY, Members, concurred in the above recommendations.

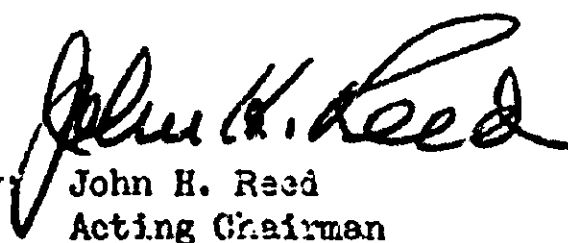
  
By John H. Reed  
Acting Chairman