



National Transportation Safety Board

Dual Hydraulic System Design and Safety Concerns

Airworthiness
presentation



Air Methods

Helicopter Rotor Controls

- Cyclic controls pitch and roll
- Collective controls total lift and thrust of main rotor
- Left and right pedals control yaw

AS350 Pedal Controls



AS350 Rotor Controls

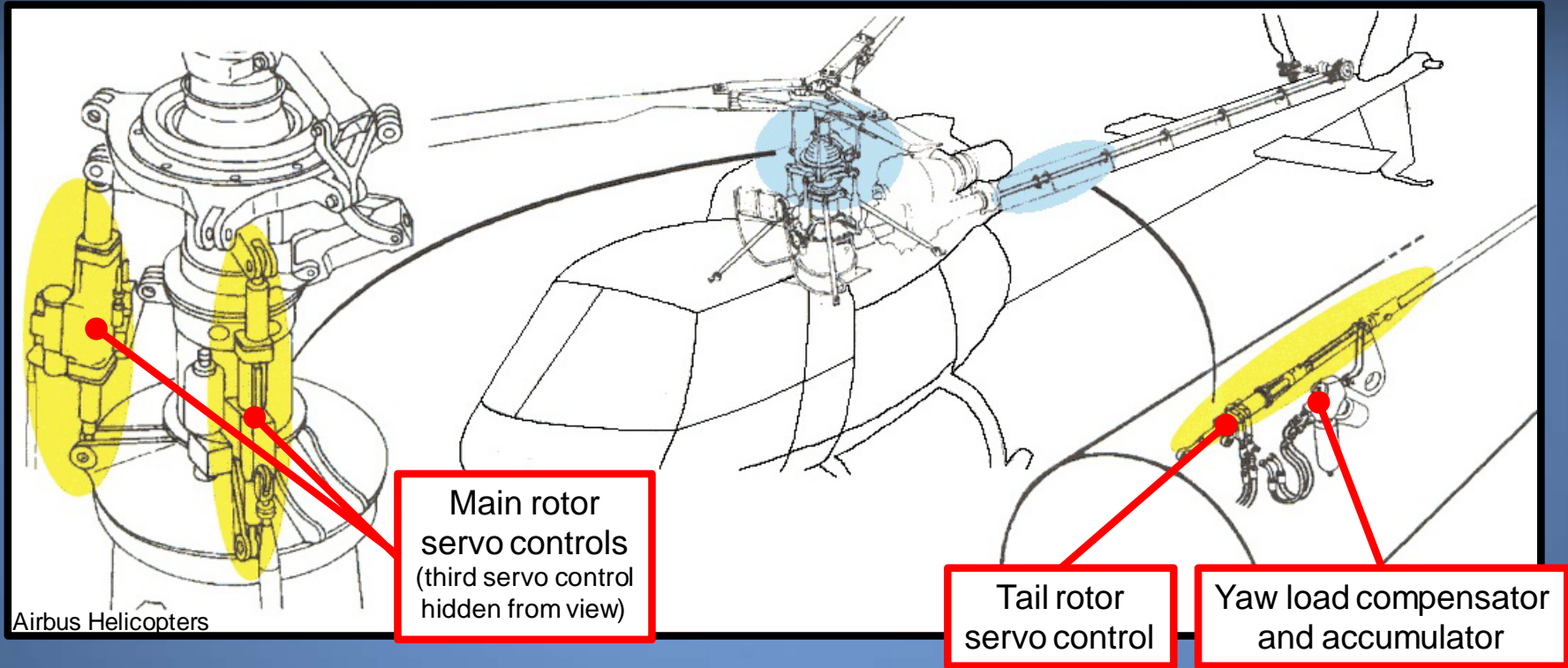

AS350 Dual Hydraulic System

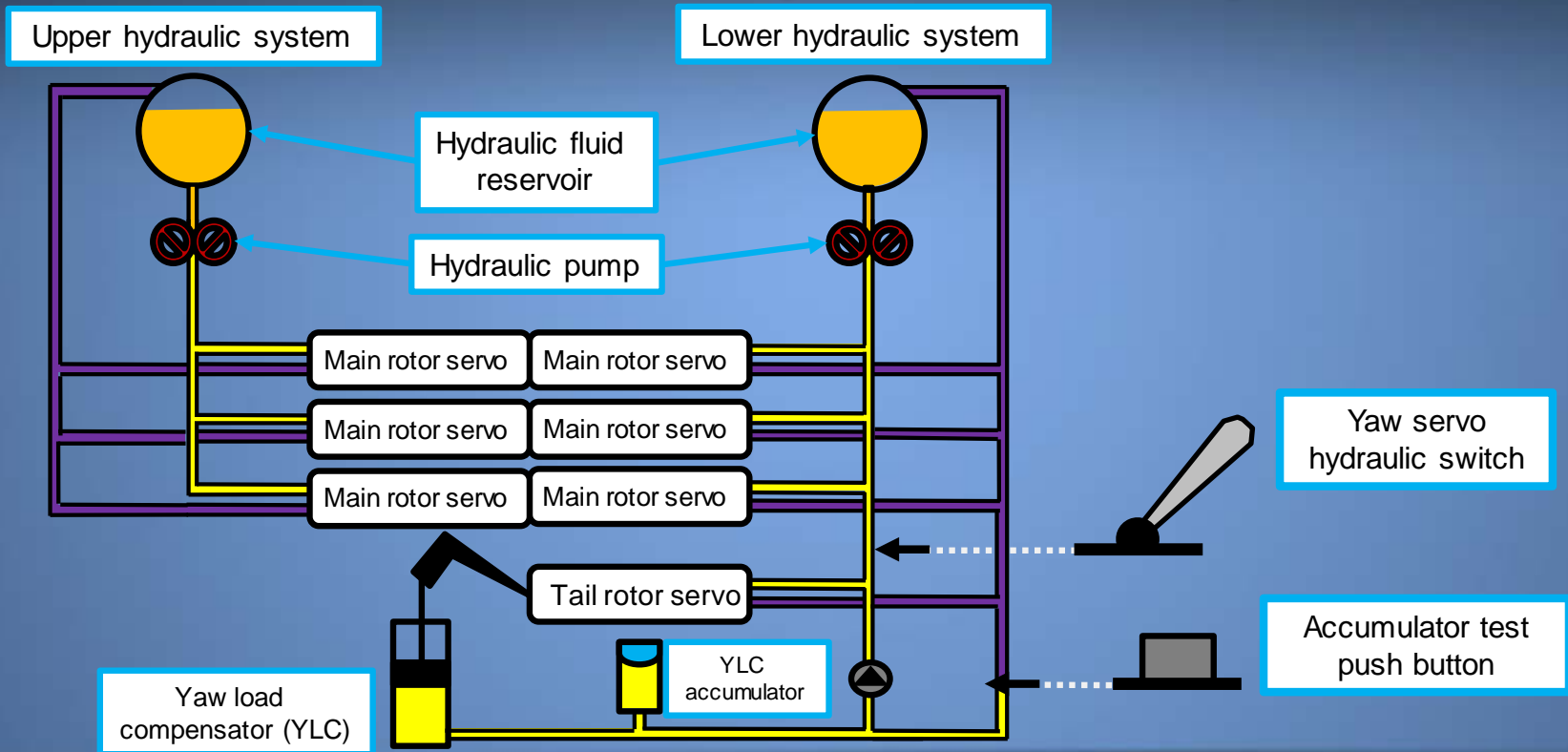

Yaw Servo Hydraulic Check

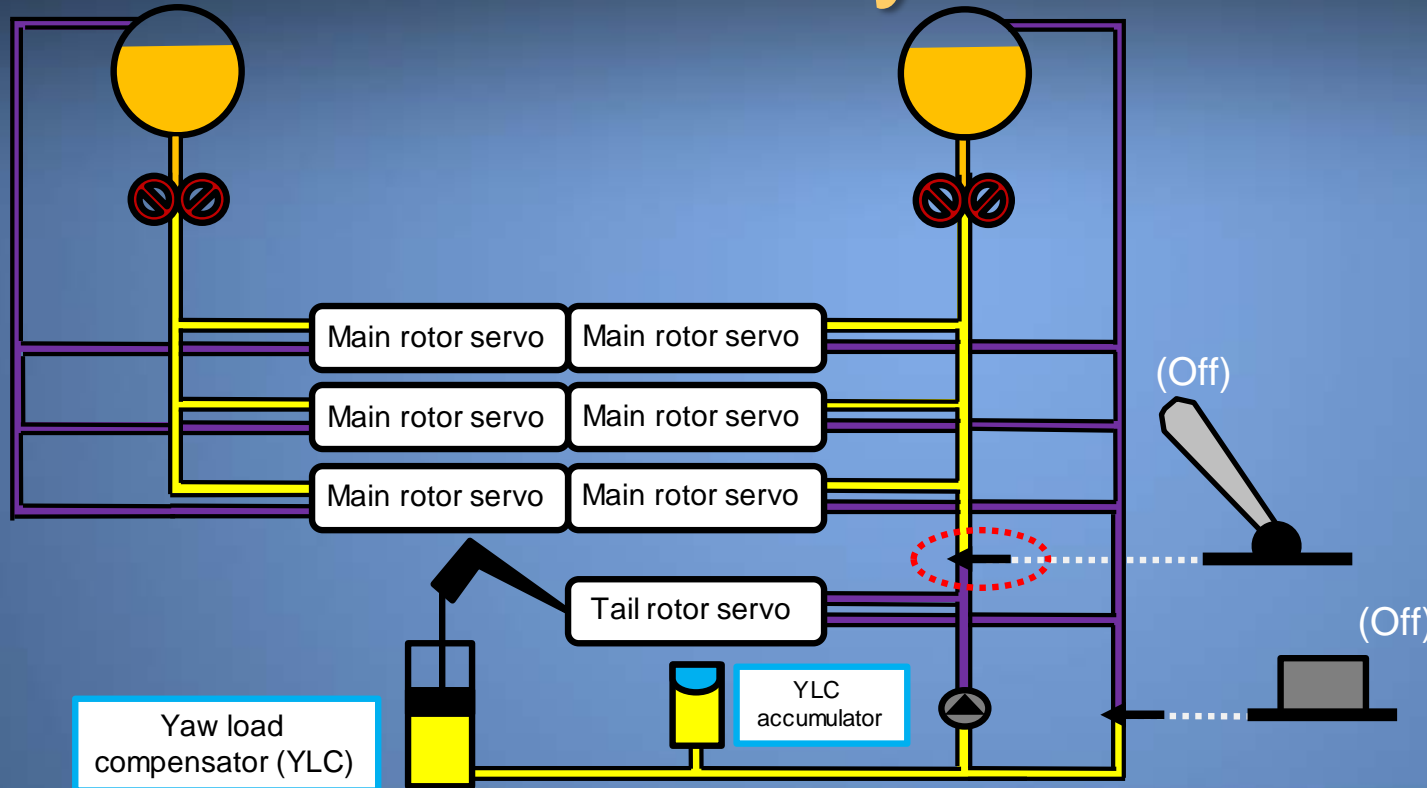

Step 1

Yaw servo hydraulic switch

Accumulator test push button

Yaw load compensator (YLC)

YLC accumulator

Yaw Servo Hydraulic Check

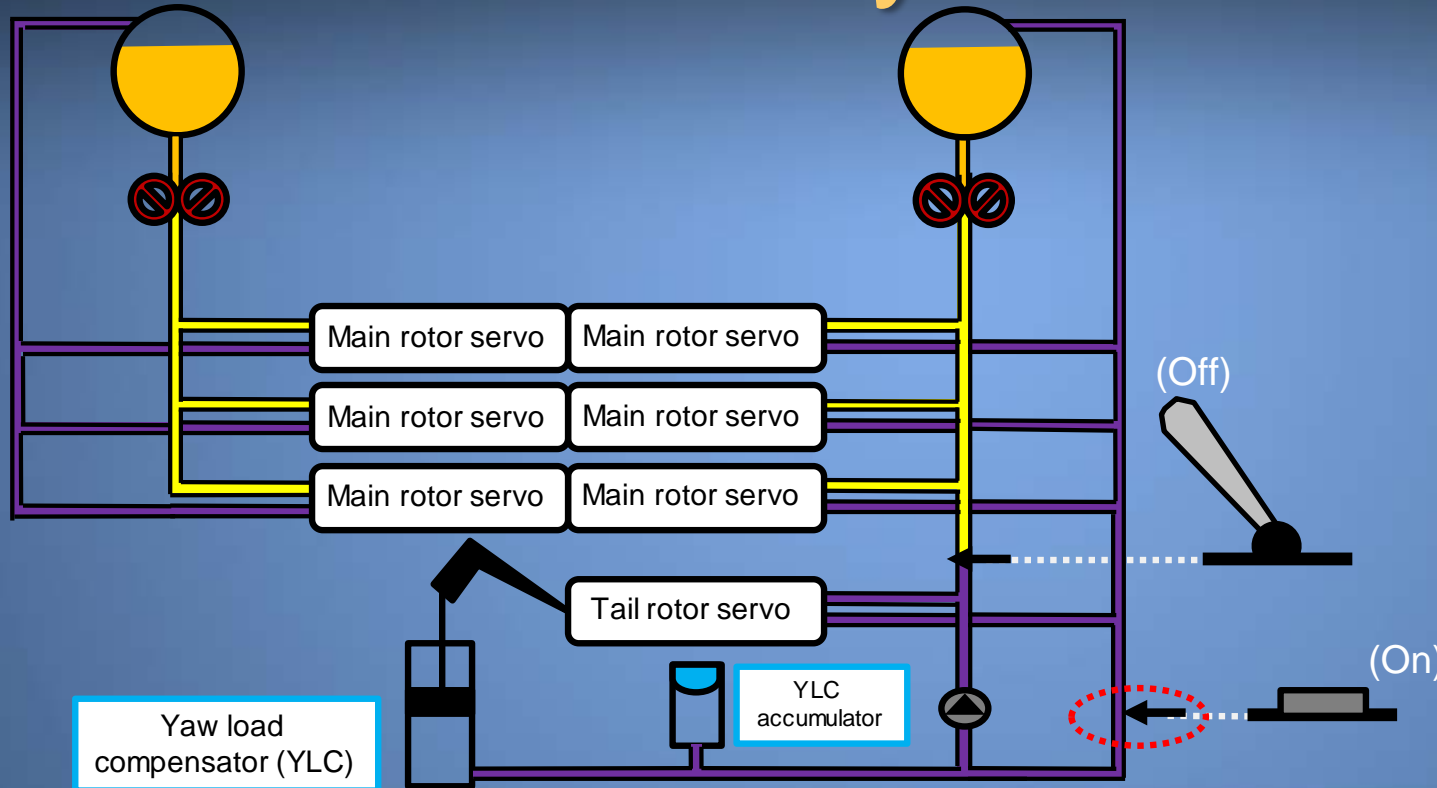

Step 2

Yaw servo hydraulic switch

Accumulator test push button

Yaw load compensator (YLC)

Tail rotor servo

YLC accumulator

Yaw Servo Hydraulic Check

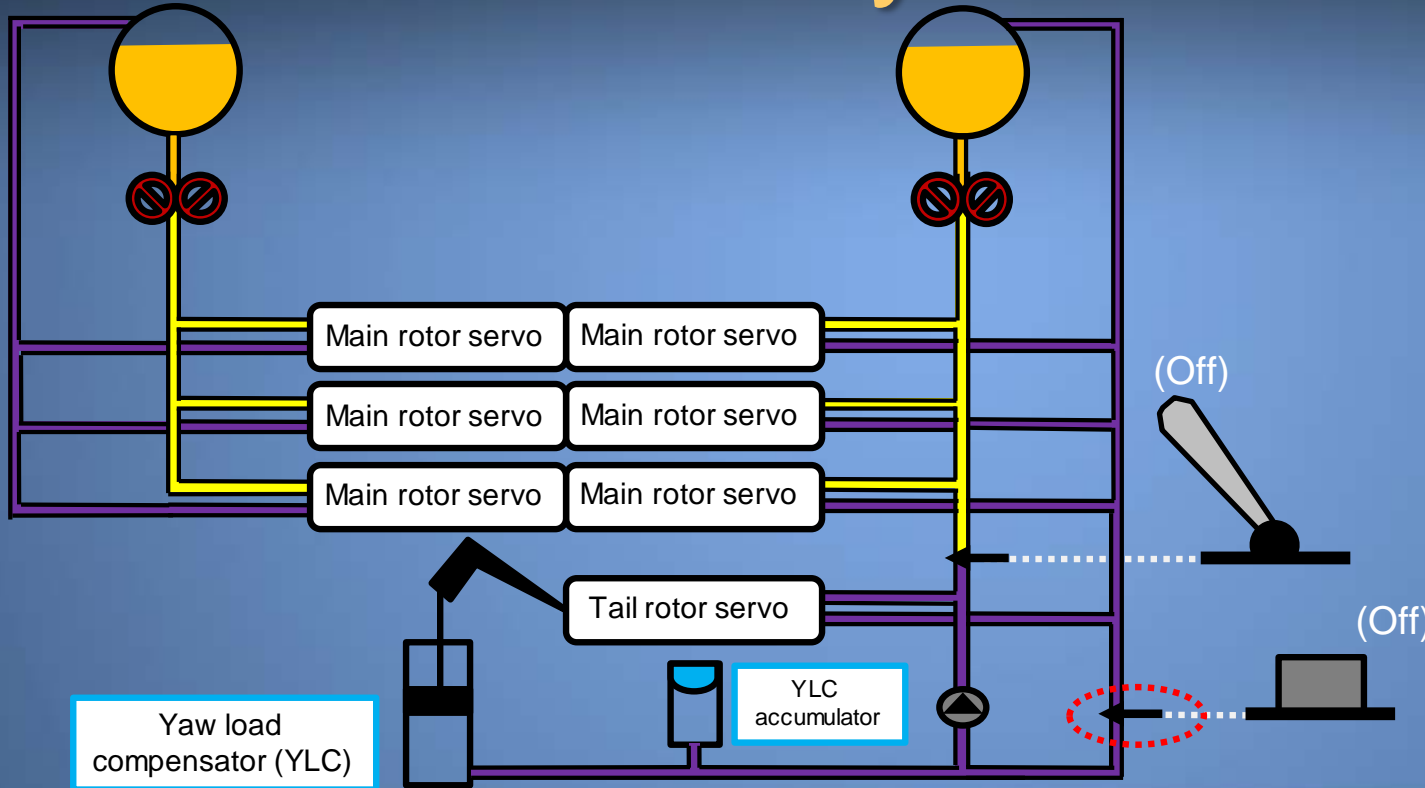

Step 3

Yaw servo hydraulic switch

Accumulator test push button

Yaw load compensator (YLC)

Tail rotor servo

YLC accumulator

Main rotor servo

Main rotor servo

Main rotor servo

Main rotor servo

Main rotor servo

Main rotor servo

(Off)

(Off)

Yaw Servo Hydraulic Check

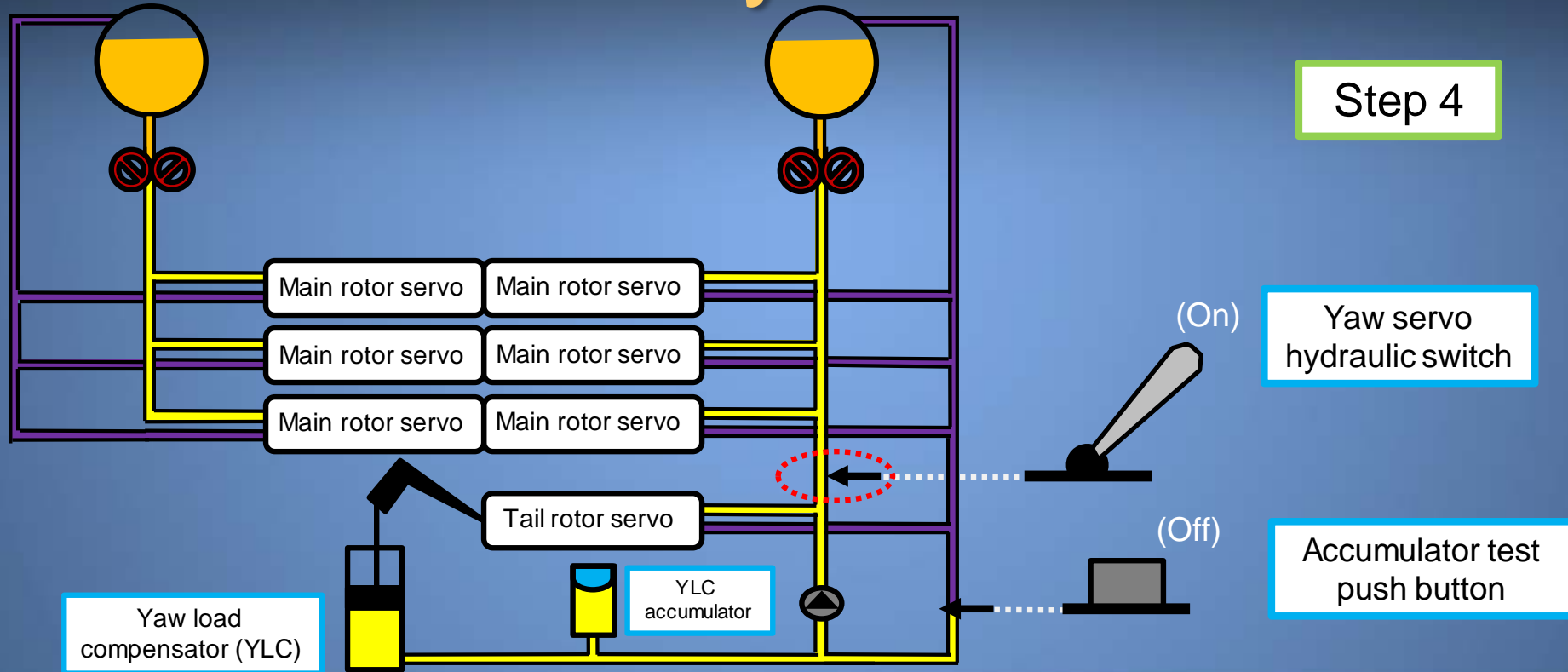

Pedal Control Anomaly

- Yaw servo hydraulic switch in off position results in high pedal forces
- Hover check can detect control anomalies, including high pedal forces

Caution Light Modification

- Airbus Helicopters released nonmandatory service bulletin for caution light modification
- Modification not incorporated into accident helicopter
- Modification does not provide alert for reduced or no pressure to tail rotor hydraulic circuit

Postflight Check Concerns

- Yaw load compensator check moved to postflight shutdown procedures
 - Assumes yaw load compensator will remain functional for next flight
 - Still relies on pilot to assess functionality of yaw load compensator via tactile check of pedal controls



National Transportation Safety Board